



**APPENDIX:**

# **DIAMOND SPORTS FIELD MANUAL**

MAY 2024



**Minneapolis  
Park & Recreation Board**

Baseball and Softball is about so much more than playing a sport or winning a game. Show everyone how much you love what the sport is truly about or how much you love watching your little one find their passion for sports.

*"You could be a kid for as long as you want when you play baseball." - Cal Ripken Jr.*



**04**

**Field Principles**  
Field Layout Principles  
Setting Up a Field  
Multiple Field Layouts

**10**

**Baseball**  
Baseball Field Dimensions  
Field Dimensions Table  
Baseball Field Classifications

**18**

**Softball**  
Softball Field Dimensions  
Field Dimensions Table  
Softball Field Classifications

**26**

**Field Materials**  
Materials Design Intent Standards  
Field Irrigation Design Intent  
Field Lighting Design Intent

\*All files and information relating to Diamond Sports can be found internally:  
[S:\Planning\Citywide\\\_MPRB STANDARDS\DIAMOND SPORTS](S:\Planning\Citywide\_MPRB STANDARDS\DIAMOND SPORTS)

# Field Layout Principles

---

Baseball and softball fields have a variety of different lines and markings that play a vital role in the game. However, there are also important differences in the overall dimensions of the field depending on the age of the participants.

With this in mind, we have created a comprehensive [Field Dimensions Table](#) that details all the dimensions and markings you can expect to see on a baseball and softball field. The guide outlines how the dimensions change from the baseball to softball, high school to collegiate, and the different age groups for each.

Baseball and softball fields are similar in design however, there are important differences between the two fields to note so that you design your field correctly.

The most obvious difference between softball and baseball fields is that the infield diamond on a softball field is much smaller than in baseball. The diamond will be 60ft long on each side, meaning there is a shorter running distance between the bases in softball. The centerfield on a softball field is closer to the home plate than on a baseball field, typically measuring between 200ft-250ft. Another key difference between the two fields is that the pitching distance is shorter on a softball field at 43ft, depending which level of play you are designing too.

Softball fields will use all dirt for their infields in comparison to a mix of grass and dirt on a baseball field. What is known as the pitcher's mound in baseball is known as the 'pitching circle' in softball, due it's flatter appearance in comparison to the raised mound in baseball.



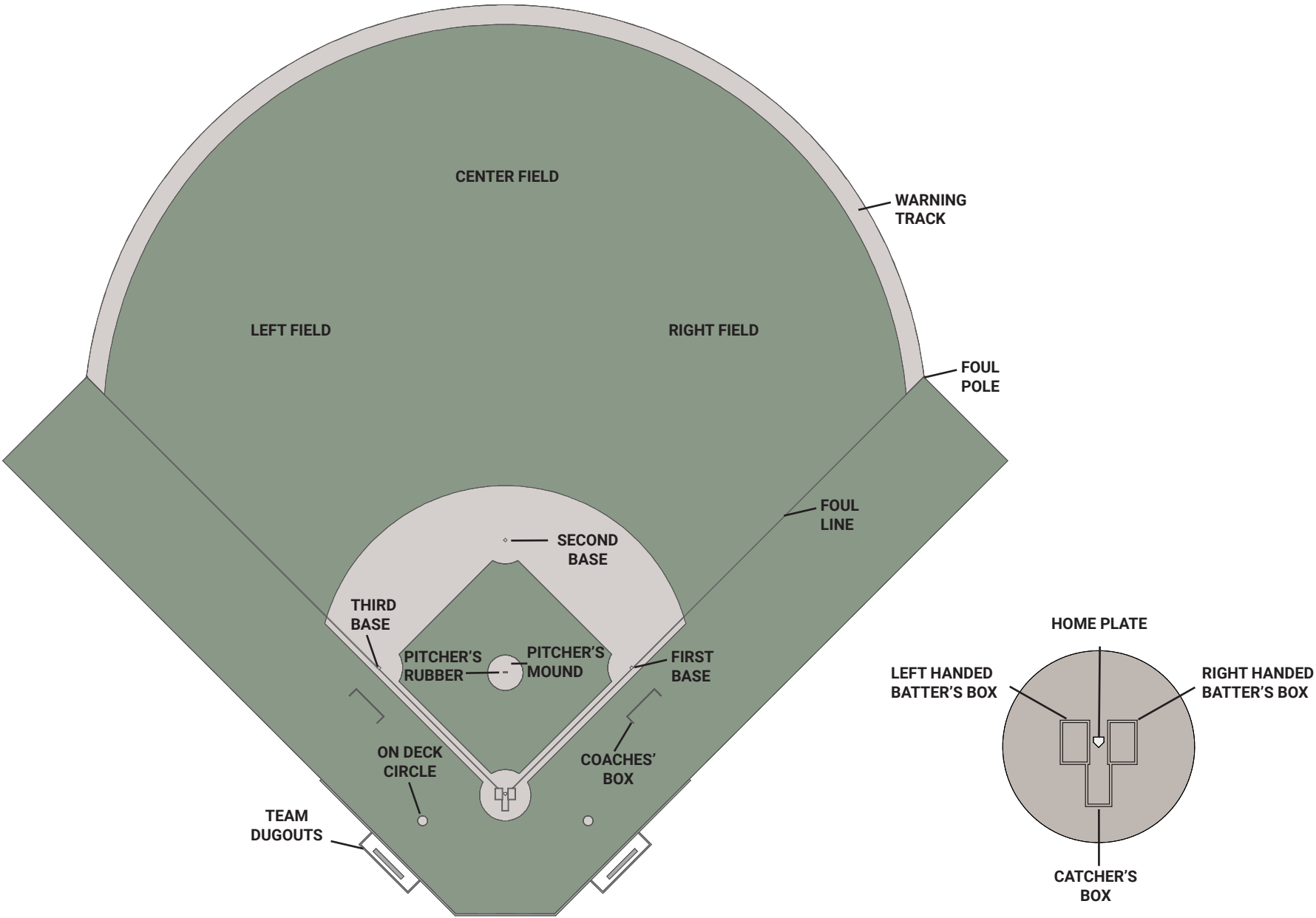

# Field Layout Principles - Setting Up A Field

## Field Orientation

Determining sun and existing site conditions impacts playability for softball and baseball. Factors to consider are slope of field, access to field, and/or sun path. The preferred field orientation places the back of the home plate facing due north to northeast, and the first baseline running west. However, optimum utilization of the site may require variations from this preferred orientation. Sun orientation can prevent the batter and catcher from looking into the sun as they stand at the plate and positions most of the fielders so that their line of sight is not directly into the setting sun. Aligning the field so that the pitcher is throwing across the sunrise/sunset line or having the field centerline home plate facing northeast for ideal orientation.



## Step 1 - Determine Home Plate Location

If there is no backstop, position the apex of home plate in an appropriate spot. For positioning the apex of home plate using an existing backstop, start from one outside corner of the backstop and run a string or tape measure out to a couple of feet past where you think the pitching rubber will be. Scribe an arc. Repeat this process starting from the second post, making sure the second string or tape is the same length as the first.

Next, measure and locate the center of the backstop. Extend a straight line from this point out to where the arcs intersect. Position the apex of home plate on this line, and depending on which type of field, a prescribed distance from the backstop.



## Step 2 - Locate Second Base

Run a line from the center point on the backstop, through the apex and over pitcher's mound to place second base on center. The distance to measure is from the apex of home plate to the center of second base.

Refer to [Field Dimensions Table \(FDT\)](#) for specific level of play and field preference.

## Step 3 - Locate 1st and 3rd Base

To find the location for 1st base, extend the measuring tape from 2nd base in the direction where the approximate location for 1st base will be. Be sure to measure using the required distance according to your league. Then, extend a second measuring tape from your home plate stake toward 1st base. You will place another stake at the point at which the two tapes intersect using equal distances from home-to-1st and 2nd-to-1st. This point will be the back outside corner of 1st base. Repeat this process to find the location of 3rd base.

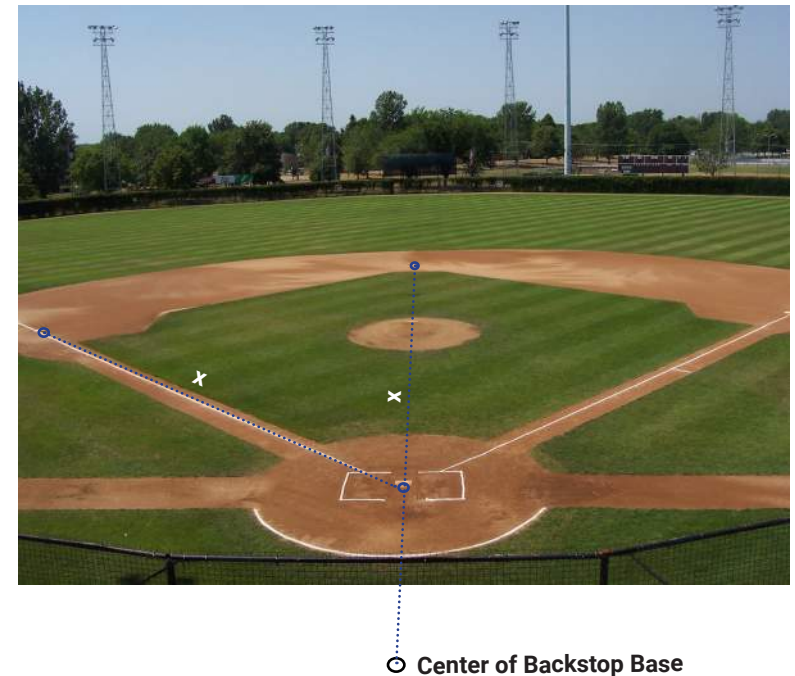

## Step 4 - Set the Pitching Mound

Now that home plate and the three bases are staked, locate the pitching mound. The center of the mound is located on the centerline of the field. The distance from home plate – [See Field Dimensions Table](#) – is always measured from the apex of the white portion of home plate to 2nd base. The black outside edging on the plate is not considered part of home plate and should not be included when measuring.

# Field Layout Principles - Setting Up A Field

## Locate the Foul Poles

To determine where the foul poles should be located, use the geometric formula for a right triangle:  $A^2 + B^2 = C^2$

To find the left field foul line, let A equal the distance between 2nd and 3rd base. Let B equal the distance the foul line will extend past 3rd base to the foul pole.

Square each of these two numbers. Then, add them together. Next, take the square root of the sum of the two numbers to calculate the length of C – the hypotenuse (follow the sample below). Once you have values for A, B and C, you can go to work on your field to triangulate the location of your foul poles.

If you have been following Steps 1-5, you have stakes set at the back corner of 3rd base and the exact center of 2nd base. Extend a 300' measuring tape from each stake. Extend the tape from the 3rd base stake to the B distance, and you will extend the tape from 2nd base to the C distance.

Pull the two measuring tapes toward each other until they are perfectly straight and intersect at the correct measurements. Place a stake at this location to mark the left field corner. This is the location of your left field foul pole.

Repeat this process for finding the right field foul pole by having A equal the distance from 1st base to 2nd base, and B equal the distance you want the foul pole to extend past 1st base.

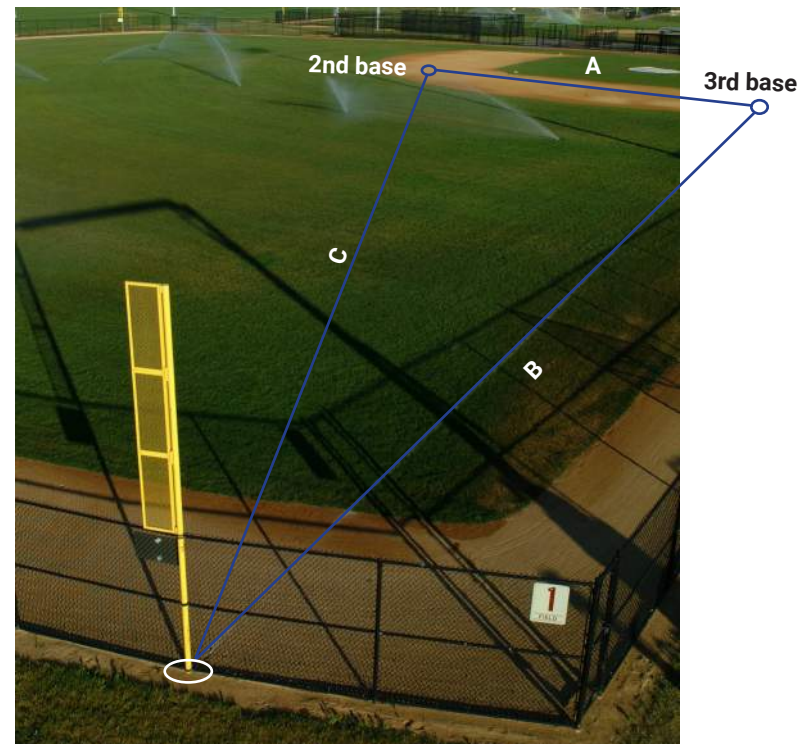
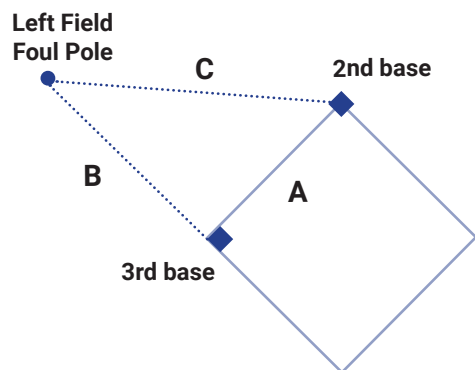

## Multiple Fields

Multiple fields being placed adjacent to one another shall be placed side-by-side. Fields may be “off-set” to facilitate field layout, but may not be end-to-end. The minimum separation between fields shall be 9 feet.

Planning for multi-field layouts should use a preferred “pinwheel” approach for efficiency and increased level of playability.



\*Baseball Fields Pinwheel Layout at Bossen Field Park



\*Neiman Sports Complex

# Baseball Field Dimensions

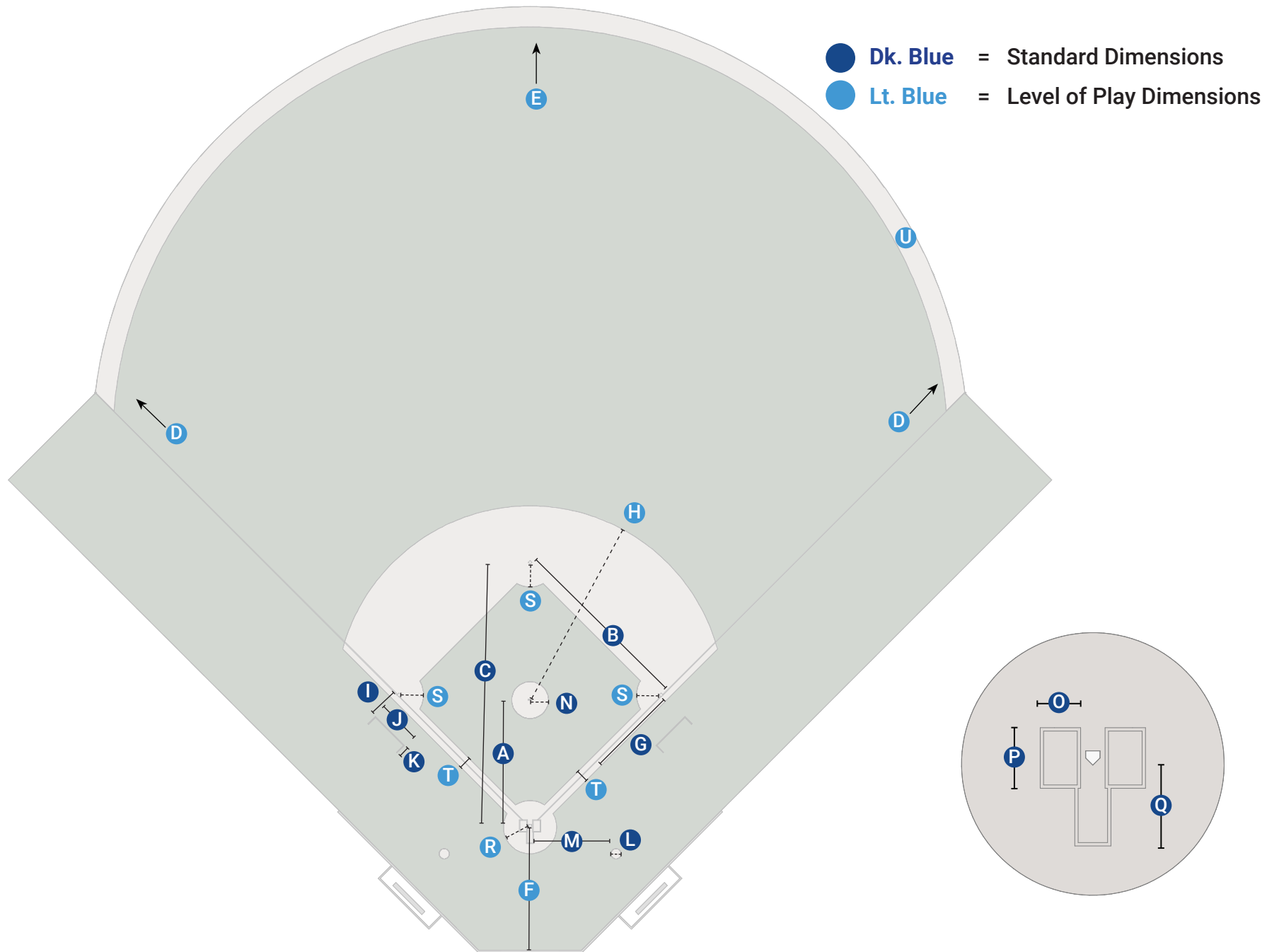

# Baseball Field Dimensions Table

League (Level of Play)	Pitching Rubber Distance	Base Lengths	Home Plate to Second Base	Outfield Fence Distance	Minimum Center Field Fence Distance	Home Plate to Backstop	1st base Runner's Lane	Infield Arc Radius	Coaches box from foul line	Coaches's box length	Coaches box width	On Deck Circle Diameter	On Deck Circle from Home Plate	Picture's Mound Radius	Batter's Box Width	Batter's Box Length	Home Plate to Catcher's Box	Home Plate Radius	Base Cut out Radius	Baseline Width (home to 1st and 3rd)	Warning Track Width - Outfield
	A	B	C	D	E	F	G	H	I	J	K	L	M	N	O	P	Q	R	S	T	U
<b>10U</b>	46'	60'	84' - 10 1/4"	200'	200'	60'	45'	95'	15'	20'	5'	5'	37'	9'	6'	4'	8'	13'	13'	6'	10'
<b>12U</b>	52'	75'	84' - 10 1/4"	250'	250'	60'	45'	95'	15'	20'	5'	5'	37'	9'	6'	4'	8'	13'	13'	6'	10'
<b>13U to 15U</b>	60' - 6"	90'	127' - 3 3/8"	300'	300'	60'	45'	95'	15'	20'	5'	5'	37'	9'	6'	4'	8'	13'	13'	6'	10'
<b>18U, High School, M</b>	60' - 6"	90'	127' - 3 3/8"	300'	400'	60'	45'	95'	15'	20'	5'	5'	37'	9'	6'	4'	8'	13'	13'	6'	10'

**Dk. Blue** = Standard Dimensions

**Lt. Blue** = Level of Play Dimensions



# Baseball Field Classifications

## Field Class

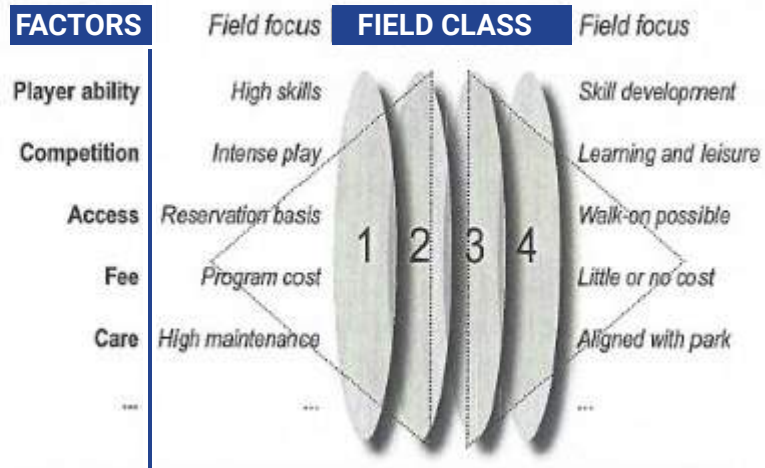

## Features Key

- REQUIRED** Feature shall be present for best play experience
- PREFERRED** Feature is desired to enhance play experience
- OPTIONAL** Feature may be present if conditions, funding, and operations are supportive and experience of play is enhanced
- NOT REQUIRED** Feature is not needed to support experience for that field's level of play

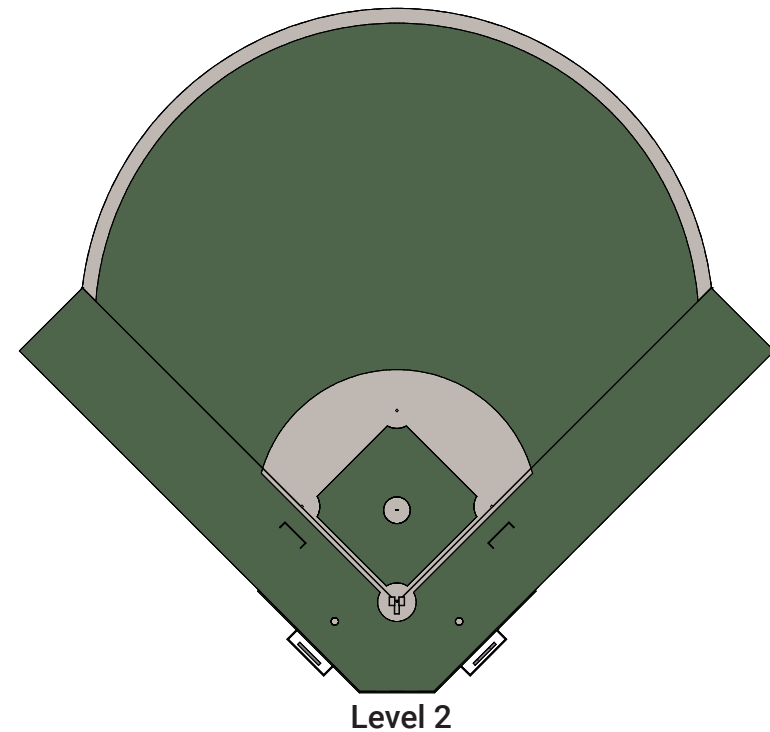
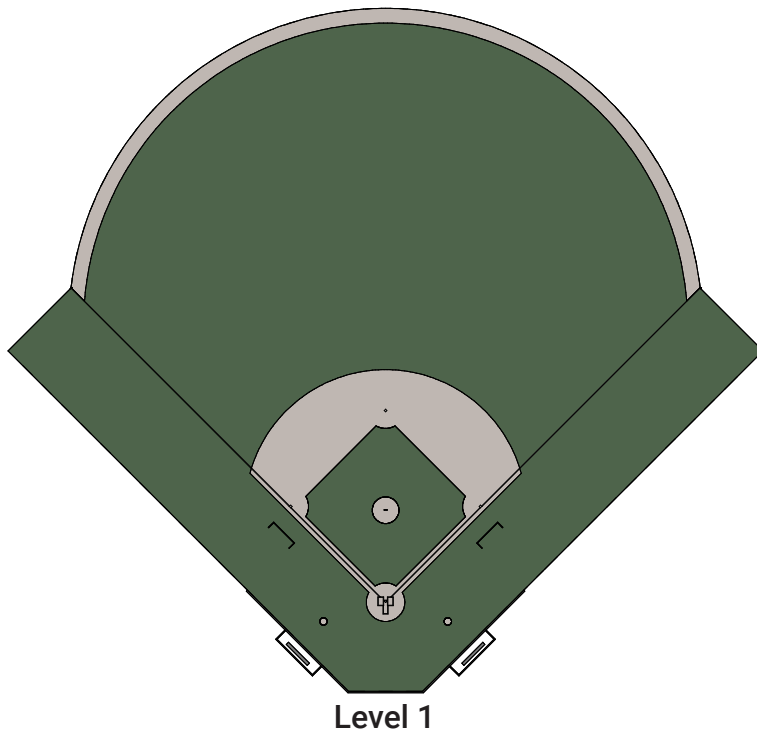

# Baseball Field Classifications and Locations

## Baseball - Level 1

BOSSEN FIELD PARK  
NEIMAN SPORTS COMPLEX  
PARADE PARK

## Baseball - Level 2

FARVIEW PARK  
NORTHEAST ATHLETIC  
FIELD PARK  
PEARL PARK  
SHINGLE CREEK PARK  
STEWART PARK  
VAN CLEVE PARK  
XCEL FIELD PARK

## Baseball - Level 3

ARMATAGE PARK  
BOTTINEAU FIELD PARK  
EAST PHILLIPS PARK  
JACKSON SQUARE PARK  
MCRAE PARK  
NORTHEAST ATHLETIC  
FIELD PARK  
PERSHING FIELD PARK  
POWDERHORN PARK  
REV. DR. MARTIN LUTHER  
KING JR. PARK  
SHINGLE CREEK PARK  
WHITTIER PARK

## Baseball - Level 4

BASSETT'S CREEK PARK  
BOHANON PARK  
BRACKET FIELD PARK  
BRYANT SQUARE PARK  
BRYN MAWR PARK  
FOLWELL PARK  
HIAWATHA SCHOOL PARK  
KEEWAYDIN PARK  
KENWOOD PARK  
LAKE HIAWATHA  
NEIGHBORHOOD PARK  
LAKE NOKOMIS REGIONAL  
PARK  
LINDEN HILLS PARK

LOGAN PARK  
LONGFELLOW PARK  
LYNNHURST PARK  
MATTHEWS PARK  
MINNEHAHA CREEK PARK  
MORRIS PARK  
NORTH COMMONS  
PAINTER PARK  
PEARL PARK  
PHELPS FIELD PARK  
SIBLEY PARK  
TODD PARK  
VAN CLEVE PARK  
WILLARD PARK  
WINDOM NORTHEAST PARK

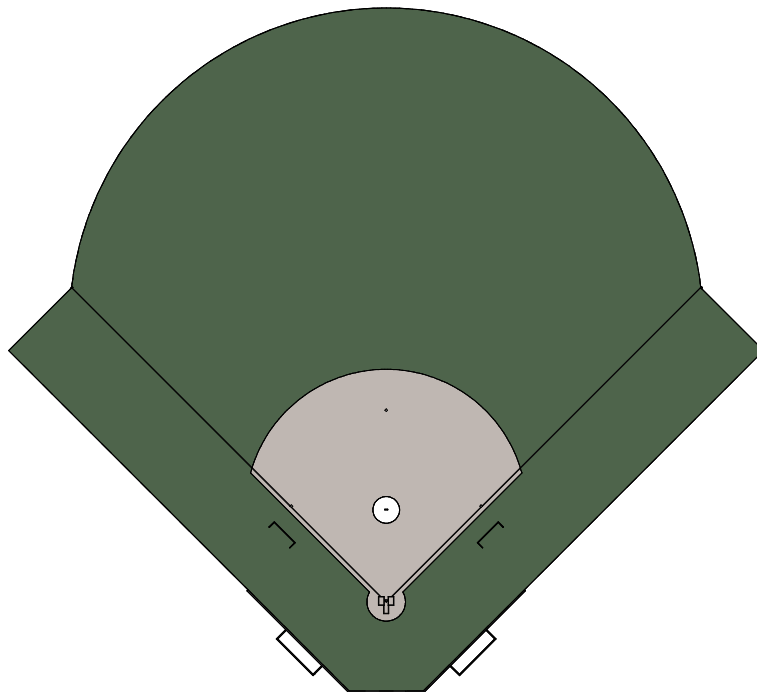

Level 3

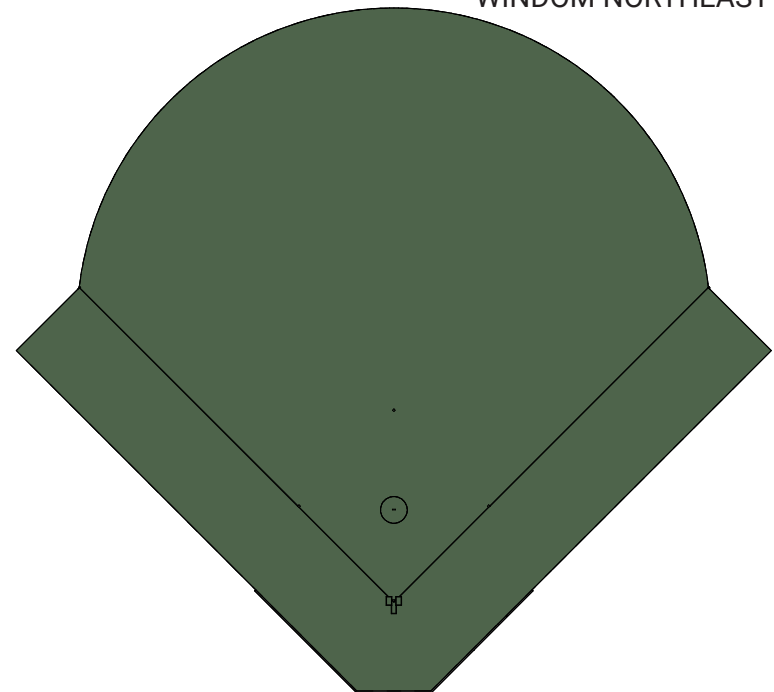

Level 4

# Baseball Field Classifications - Level 1

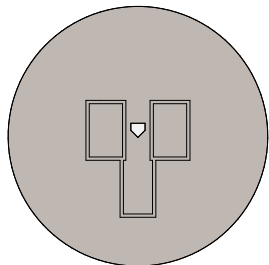
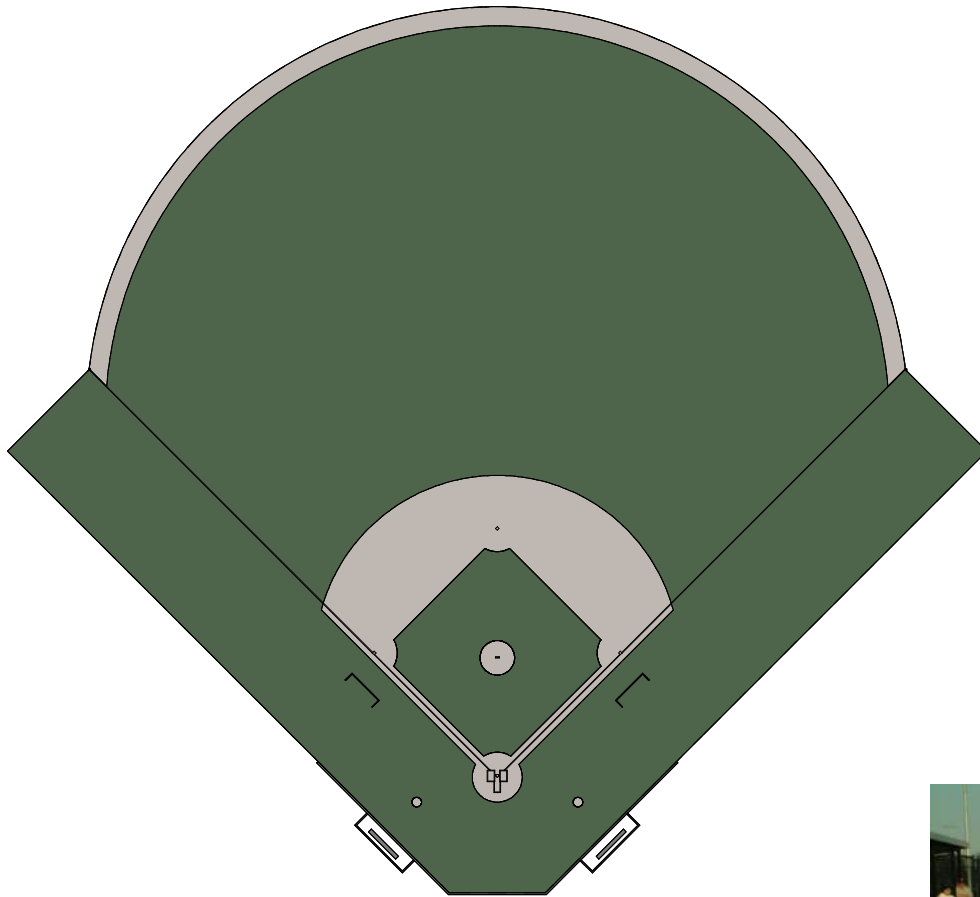

	Field Class			
	1	2	3	4
<b>Player Safety</b>				
Safety Fencing at Players Bench	REQ	REQ	REQ	REQ
Safety Fencing at Bullpen	REQ	PREF	OPT	NOT REQ
Non-overlapping Field	REQ	REQ	OPT	NOT REQ
<b>Field Characteristics</b>				
Lighting	REQ	REQ	PREF	NOT REQ
Outfield Fencing	N/A	REQ	OPT	NOT REQ
Semi-permanent Outfield Fencing	REQ	REQ	OPT	NOT REQ
Foul Line Poles	REQ	REQ	OPT	NOT REQ
Warning Track	REQ	PREF	OPT	NOT REQ
<b>Play Characteristics</b>				
Full Backstop	REQ	REQ	PREF	OPT
Adjustable Bases	REQ	REQ	PREF	OPT
Permanent Bases	REQ	REQ	PREF	OPT
Scoreboard	REQ	REQ	NOT REQ	NOT REQ
Dugouts	REQ	REQ	REQ	OPT
Players Benches	REQ	REQ	PREF	OPT
Drinking Fountain	REQ	REQ	PREF	OPT
Electricity Source	REQ	REQ	PREF	OPT
Batting Cage	REQ	REQ	PREF	OPT
Team Equipment Shed	REQ	PREF	NOT REQ	NOT REQ
<b>Maintenance</b>				
Field Equipment Shed	REQ	REQ	OPT	NOT REQ
Irrigation	REQ	REQ	NOT REQ	NOT REQ
Weed-free Infield	REQ	REQ	REQ	PREF
Rain Cover	REQ	REQ	NOT REQ	NOT REQ
<b>Spectating</b>				
Seating	REQ	REQ	OPT	NOT REQ
Protected Seating	REQ	REQ	OPT	NOT REQ
Covered Seating	REQ	REQ	NOT REQ	NOT REQ
Concessions	REQ	OPT	NOT REQ	NOT REQ

\* REQ = Required PREF = Preferred OPT = Optional NOT REQ = Not Required N/A = Not Available



\* Neiman Sports Complex

# Baseball Field Classifications - Level 2

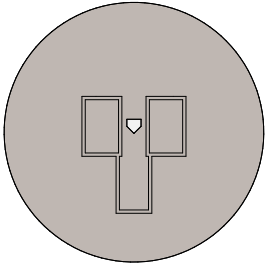
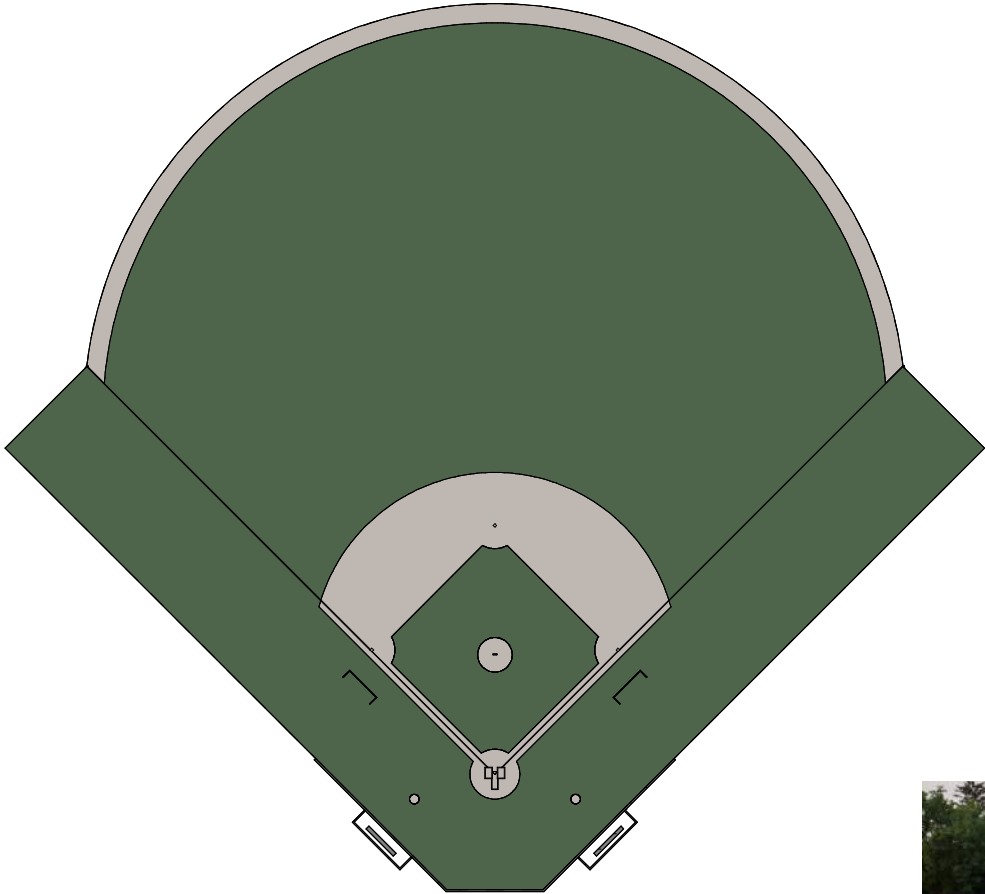

	Field Class			
	1	2	3	4
<b>Player Safety</b>				
Safety Fencing at Players Bench	REQ	REQ	REQ	REQ
Safety Fencing at Bullpen	REQ	PREF	OPT	NOT REQ
Non-overlapping Field	REQ	REQ	OPT	NOT REQ
<b>Field Characteristics</b>				
Lighting	REQ	REQ	PREF	NOT REQ
Outfield Fencing	N/A	REQ	OPT	NOT REQ
Semi-permanent Outfield Fencing	REQ	REQ	OPT	NOT REQ
Foul Line Poles	REQ	REQ	OPT	NOT REQ
Warning Track	REQ	PREF	OPT	NOT REQ
<b>Play Characteristics</b>				
Full Backstop	REQ	REQ	PREF	OPT
Adjustable Bases	REQ	REQ	PREF	OPT
Permanent Bases	REQ	REQ	PREF	OPT
Scoreboard	REQ	REQ	NOT REQ	NOT REQ
Dugouts	REQ	REQ	REQ	OPT
Players Benches	REQ	REQ	PREF	OPT
Drinking Fountain	REQ	REQ	PREF	OPT
Electricity Source	REQ	REQ	PREF	OPT
Batting Cage	REQ	REQ	PREF	OPT
Team Equipment Shed	REQ	PREF	NOT REQ	NOT REQ
<b>Maintenance</b>				
Field Equipment Shed	REQ	REQ	OPT	NOT REQ
Irrigation	REQ	REQ	NOT REQ	NOT REQ
Weed-free Infield	REQ	REQ	REQ	PREF
Rain Cover	REQ	REQ	NOT REQ	NOT REQ
<b>Spectating</b>				
Seating	REQ	REQ	OPT	NOT REQ
Protected Seating	REQ	REQ	OPT	NOT REQ
Covered Seating	REQ	REQ	NOT REQ	NOT REQ
Concessions	REQ	OPT	NOT REQ	NOT REQ

\* REQ = Required PREF = Preferred OPT = Optional NOT REQ = Not Required N/A = Not Available



\* Twins Takeover at Pearl Park

# Baseball Field Classifications - Level 3

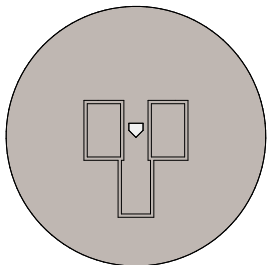
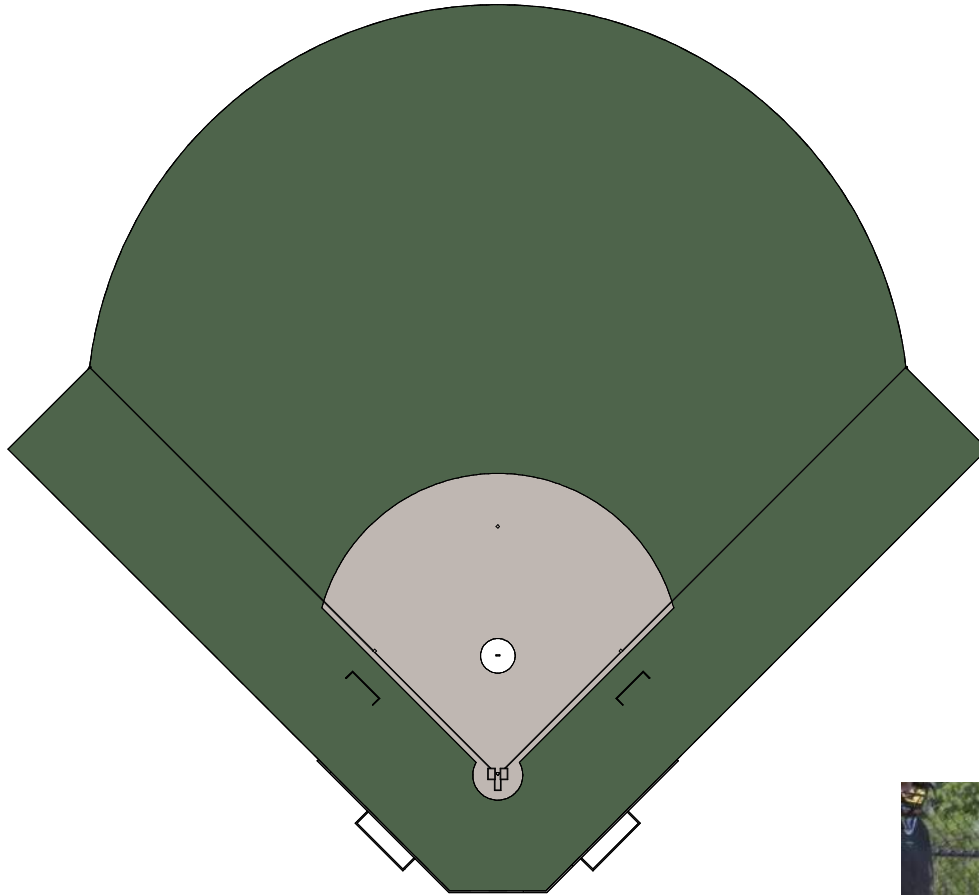

	Field Class			
	1	2	3	4
<b>Player Safety</b>				
Safety Fencing at Players Bench	REQ	REQ	REQ	REQ
Safety Fencing at Bullpen	REQ	PREF	OPT	NOT REQ
Non-overlapping Field	REQ	REQ	OPT	NOT REQ
<b>Field Characteristics</b>				
Lighting	REQ	REQ	PREF	NOT REQ
Outfield Fencing	N/A	REQ	OPT	NOT REQ
Semi-permanent Outfield Fencing	REQ	REQ	OPT	NOT REQ
Foul Line Poles	REQ	REQ	OPT	NOT REQ
Warning Track	REQ	PREF	OPT	NOT REQ
<b>Play Characteristics</b>				
Full Backstop	REQ	REQ	PREF	OPT
Adjustable Bases	REQ	REQ	PREF	OPT
Permanent Bases	REQ	REQ	PREF	OPT
Scoreboard	REQ	REQ	NOT REQ	NOT REQ
Dugouts	REQ	REQ	REQ	OPT
Players Benches	REQ	REQ	PREF	OPT
Drinking Fountain	REQ	REQ	PREF	OPT
Electricity Source	REQ	REQ	PREF	OPT
Batting Cage	REQ	REQ	PREF	OPT
Team Equipment Shed	REQ	PREF	NOT REQ	NOT REQ
<b>Maintenance</b>				
Field Equipment Shed	REQ	REQ	OPT	NOT REQ
Irrigation	REQ	REQ	NOT REQ	NOT REQ
Weed-free Infield	REQ	REQ	REQ	PREF
Rain Cover	REQ	REQ	NOT REQ	NOT REQ
<b>Spectating</b>				
Seating	REQ	REQ	OPT	NOT REQ
Protected Seating	REQ	REQ	OPT	NOT REQ
Covered Seating	REQ	REQ	NOT REQ	NOT REQ
Concessions	REQ	OPT	NOT REQ	NOT REQ

\* REQ = Required PREF = Preferred OPT = Optional NOT REQ = Not Required N/A = Not Available



\* Youth Baseball at Bottineau Field Park

# Baseball Field Classifications - Level 4

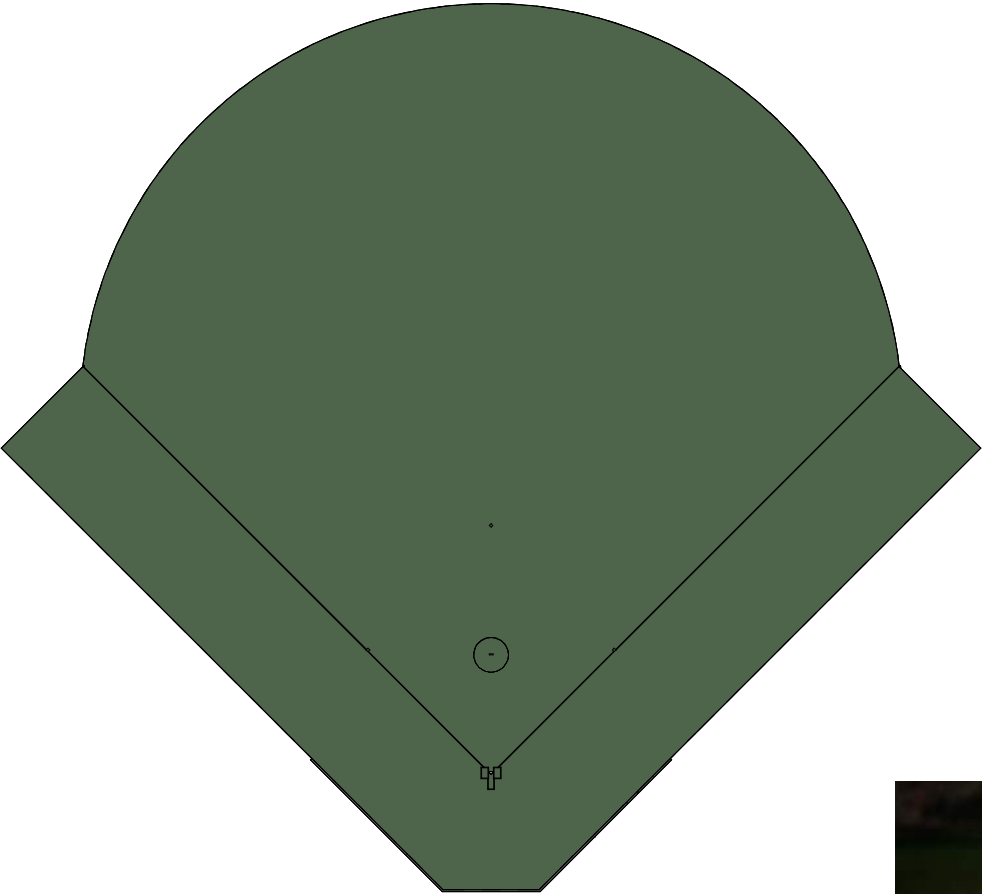

	Field Class			
	1	2	3	4
<b>Player Safety</b>				
Safety Fencing at Players Bench	REQ	REQ	REQ	REQ
Safety Fencing at Bullpen	REQ	PREF	OPT	NOT REQ
Non-overlapping Field	REQ	REQ	OPT	NOT REQ
<b>Field Characteristics</b>				
Lighting	REQ	REQ	PREF	NOT REQ
Outfield Fencing	N/A	REQ	OPT	NOT REQ
Semi-permanent Outfield Fencing	REQ	REQ	OPT	NOT REQ
Foul Line Poles	REQ	REQ	OPT	NOT REQ
Warning Track	REQ	PREF	OPT	NOT REQ
<b>Play Characteristics</b>				
Full Backstop	REQ	REQ	PREF	OPT
Adjustable Bases	REQ	REQ	PREF	OPT
Permanent Bases	REQ	REQ	PREF	OPT
Scoreboard	REQ	REQ	NOT REQ	NOT REQ
Dugouts	REQ	REQ	REQ	OPT
Players Benches	REQ	REQ	PREF	OPT
Drinking Fountain	REQ	REQ	PREF	OPT
Electricity Source	REQ	REQ	PREF	OPT
Batting Cage	REQ	REQ	PREF	OPT
Team Equipment Shed	REQ	PREF	NOT REQ	NOT REQ
<b>Maintenance</b>				
Field Equipment Shed	REQ	REQ	OPT	NOT REQ
Irrigation	REQ	REQ	NOT REQ	NOT REQ
Weed-free Infield	REQ	REQ	REQ	PREF
Rain Cover	REQ	REQ	NOT REQ	NOT REQ
<b>Spectating</b>				
Seating	REQ	REQ	OPT	NOT REQ
Protected Seating	REQ	REQ	OPT	NOT REQ
Covered Seating	REQ	REQ	NOT REQ	NOT REQ
Concessions	REQ	OPT	NOT REQ	NOT REQ

\* REQ = Required PREF = Preferred OPT = Optional NOT REQ = Not Required N/A = Not Available

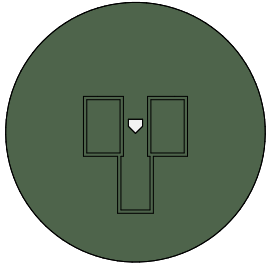

\*Youth Sports Clinic at Morris Park

# Softball Field Dimensions

- Dk. Blue** = Standard Dimensions
- Lt. Blue** = Level of Play Dimensions

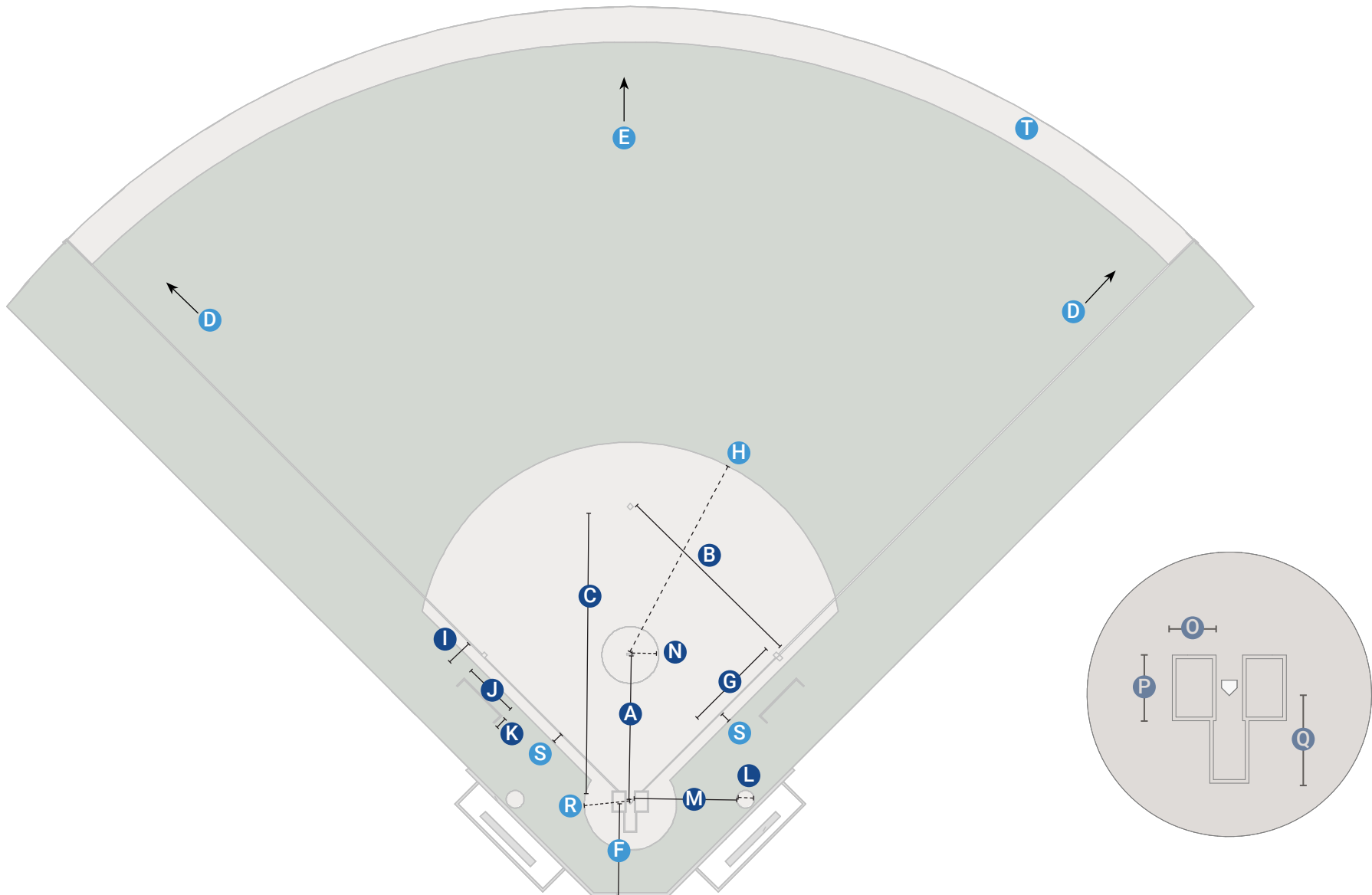

# Softball Field Dimensions Table

	Pitching Rubber Distance	Base Lengths	Home Plate to Second Base	Outfield Fence Min. Distance	Outfield Fence Max. Distance	Home Plate to Backstop	1st base Runner's Lane	Infield Arc Radius	Coaches box from foul line	Coaches's box length	Coaches box width	On Deck Circle Diameter	On Deck Circle from Home Plate	Picture's Mound Radius	Batter's Box Width	Batter's Box Length	Home Plate to Catcher's Box	Home Plate Radius	Baseline Width (foul line to grass)	Warning Track Width - Outfield
League (Level of Play)	A	B	C	D	E	F	G	H	I	J	K	L	M	N	O	P	Q	R	S	T
12U & 14U (fast pitch)	40'	60'	84' - 10 1/4"	200'	225'	25'	30'	65'	8	15'	3'	5'	30'	8'	6'	4'	8'	13'	6'	10'
12U (slow pitch)	46'	60'	84' - 10 1/4"	175'	200'	25'	30'	65'	8	15'	3'	5'	30'	8'	6'	4'	8'	13'	6'	10'
14U, 16U & 18U (slow pitch)	50'	60'	91' - 11"	225'	250'	25'	30'	65'	8	15'	3'	5'	30'	8'	6'	4'	8'	13'	6'	10'
High School, Womens, & College (fast pitch)	43'	60'	84' - 10 1/4"	200'	225'	25'	30'	65'	8	15'	3'	5'	30'	8'	6'	4'	8'	13'	6'	10'
Mens (fast pitch)	46'	60'	84' - 10 1/4"	225'	275'	25'	30'	65'	8	15'	3'	5'	30'	8'	6'	4'	8'	13'	6'	10'
Adult (slow pitch)	50'	60'	99'	275'	300'	25'	30'	65'	8	15'	3'	5'	30'	8'	6'	4'	8'	13'	6'	10'

**Dk. Blue** = Standard Dimensions

**Lt. Blue** = Level of Play Dimensions



# Softball Field Classifications

## Field Class

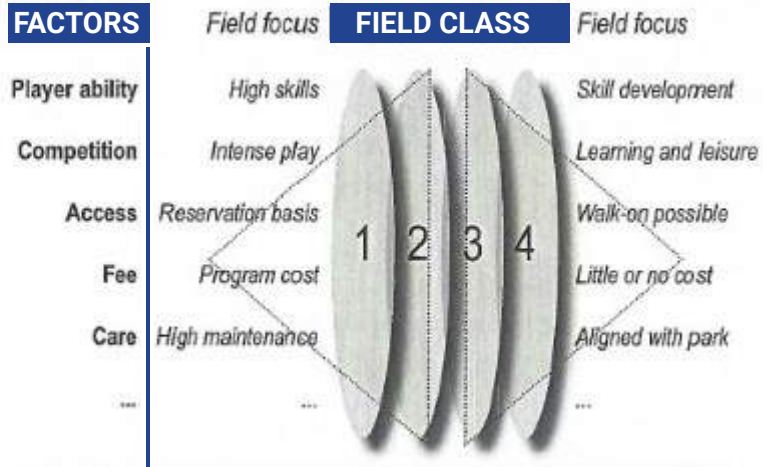

## Features Key

- REQUIRED** Feature shall be present for best play experience
- PREFERRED** Feature is desired to enhance play experience
- OPTIONAL** Feature may be present if conditions, funding, and operations are supportive and experience of play is enhanced
- NOT REQUIRED** Feature is not needed to support experience for that field's level of play

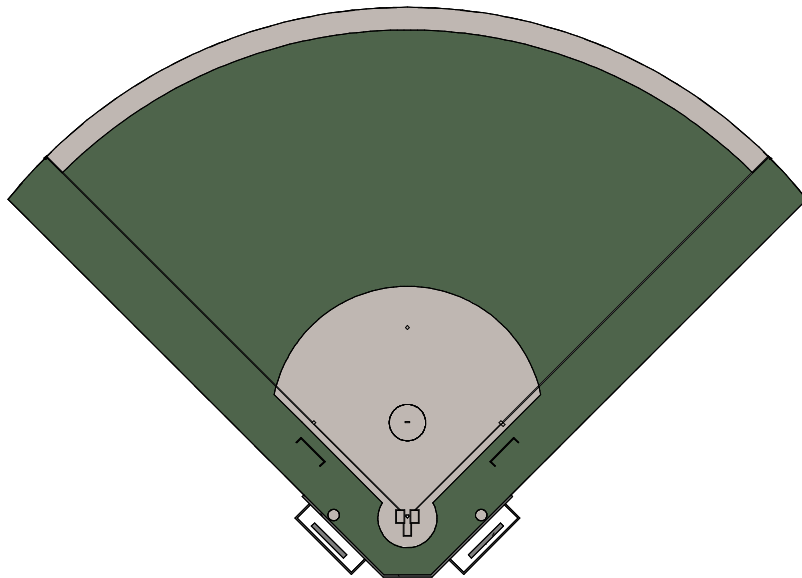

Level 1

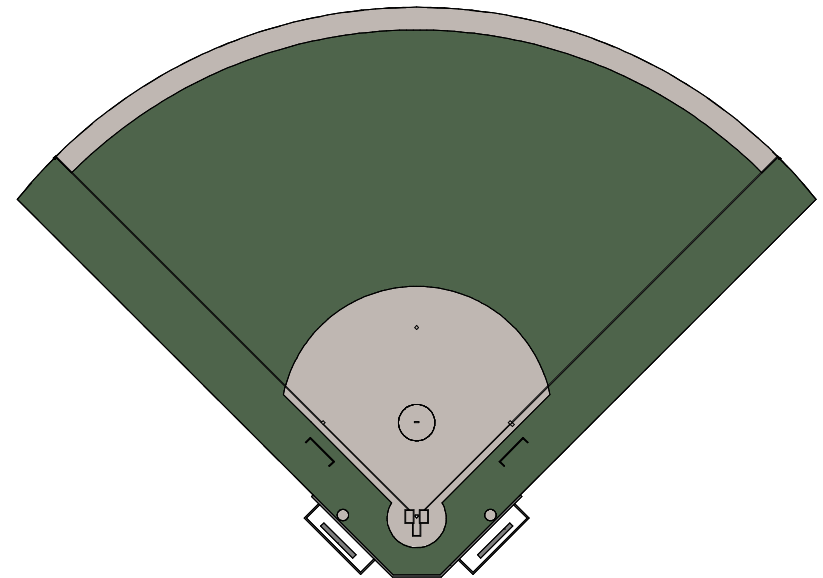

Level 2

# Softball Field Classifications and Locations

## Softball - Level 1

TBD

## Softball - Level 2

XCEL FIELD PARK  
PEARL PARK

## Softball - Level 3

BOTTINEAU FIELD PARK

## Softball - Level 4

AUTUBON PARK  
BRYN MAWR MEADOWS PARK  
MARSHALL TERRACE PARK  
WAITE PARK  
LAKE NOKOMIS REGIONAL PARK  
PEARL PARK

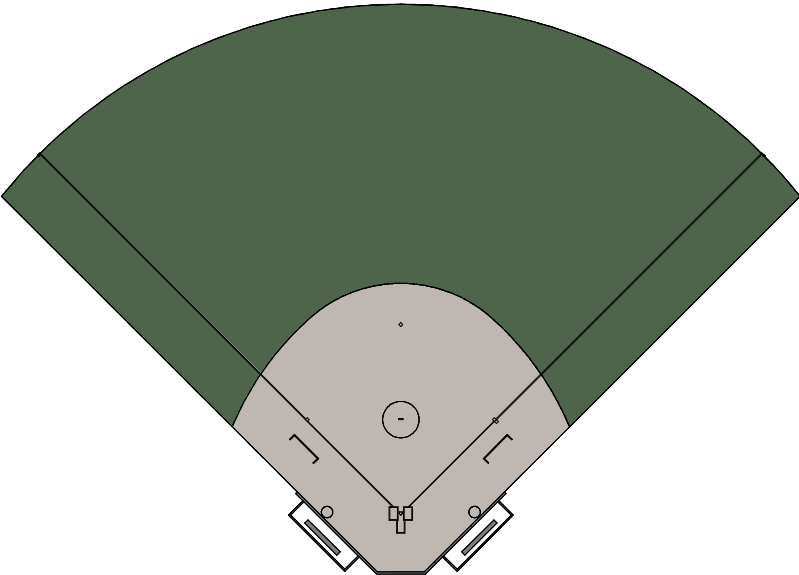

Level 3

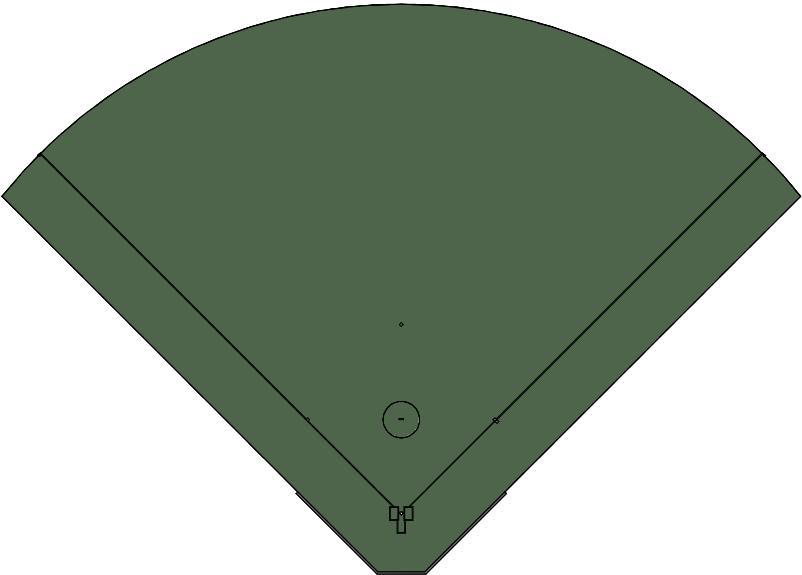

Level 4

# Softball Field Classifications - Level 1

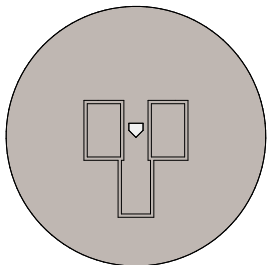
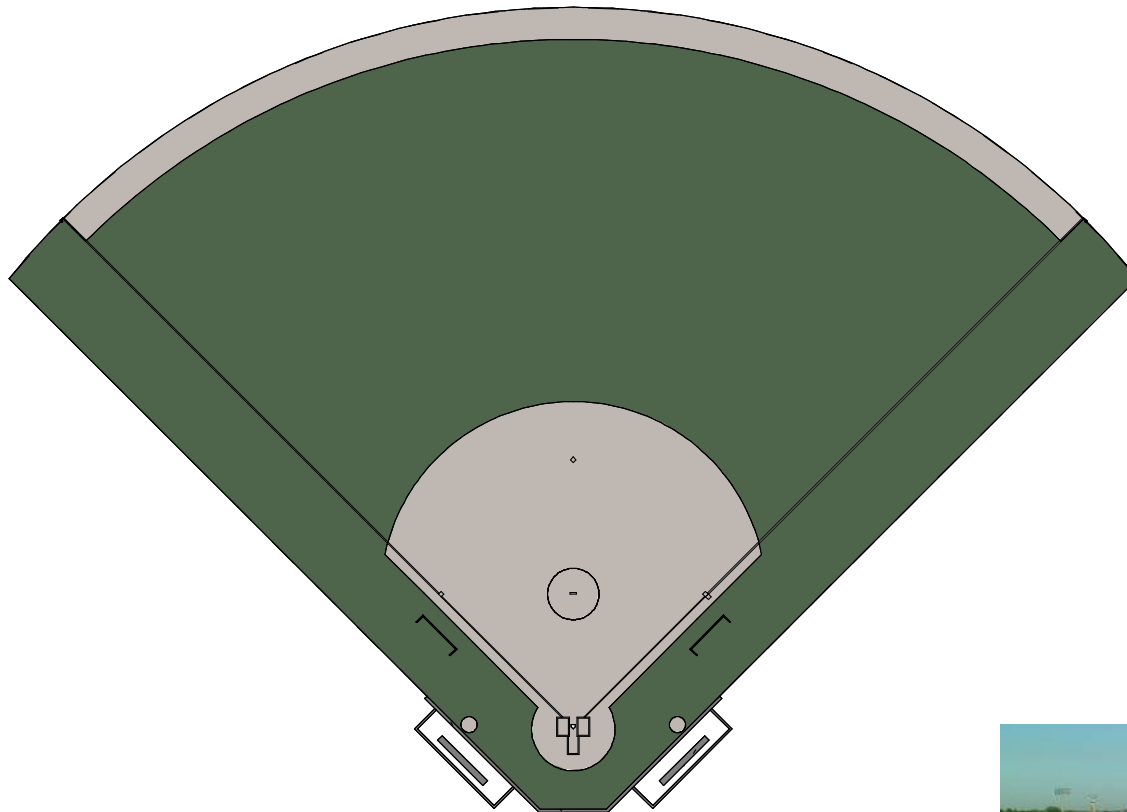

	Field Class			
	1	2	3	4
<b>Player Safety</b>				
Safety Fencing at Players Bench	REQ	REQ	REQ	REQ
Safety Fencing at Bullpen	REQ	PREF	OPT	NOT REQ
Non-overlapping Field	REQ	REQ	OPT	NOT REQ
<b>Field Characteristics</b>				
Lighting	REQ	REQ	PREF	NOT REQ
Outfield Fencing	REQ	REQ	OPT	NOT REQ
Semi-permanent Outfield Fencing	REQ	REQ	OPT	NOT REQ
Foul Line Poles	REQ	REQ	OPT	NOT REQ
Warning Track	REQ	PREF	OPT	NOT REQ
<b>Play Characteristics</b>				
Full Backstop	REQ	REQ	PREF	OPT
Adjustable Bases	REQ	REQ	PREF	OPT
Permanent Bases	REQ	REQ	PREF	OPT
Scoreboard	REQ	REQ	NOT REQ	NOT REQ
Dugouts	REQ	REQ	REQ	OPT
Players Benches	REQ	REQ	PREF	OPT
Drinking Fountain	REQ	REQ	PREF	OPT
Electricity Source	REQ	REQ	PREF	OPT
Batting Cage	REQ	REQ	PREF	OPT
Team Equipment Shed	REQ	PREF	NOT REQ	NOT REQ
<b>Maintenance</b>				
Field Equipment Shed	REQ	REQ	OPT	NOT REQ
Irrigation	REQ	REQ	NOT REQ	NOT REQ
Weed-free Infield	REQ	REQ	REQ	PREF
Rain Cover	REQ	REQ	NOT REQ	NOT REQ
<b>Spectating</b>				
Seating	REQ	REQ	OPT	NOT REQ
Protected Seating	REQ	REQ	OPT	NOT REQ
Covered Seating	REQ	REQ	NOT REQ	NOT REQ
Concessions	REQ	OPT	NOT REQ	NOT REQ

\* REQ = Required PREF = Preferred OPT = Optional NOT REQ = Not Required N/A = Not Available



\* Neiman Sports Complex

# Softball Field Classifications - Level 2

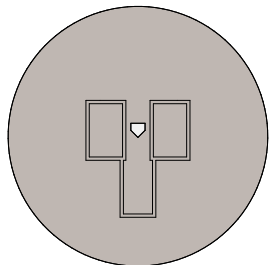
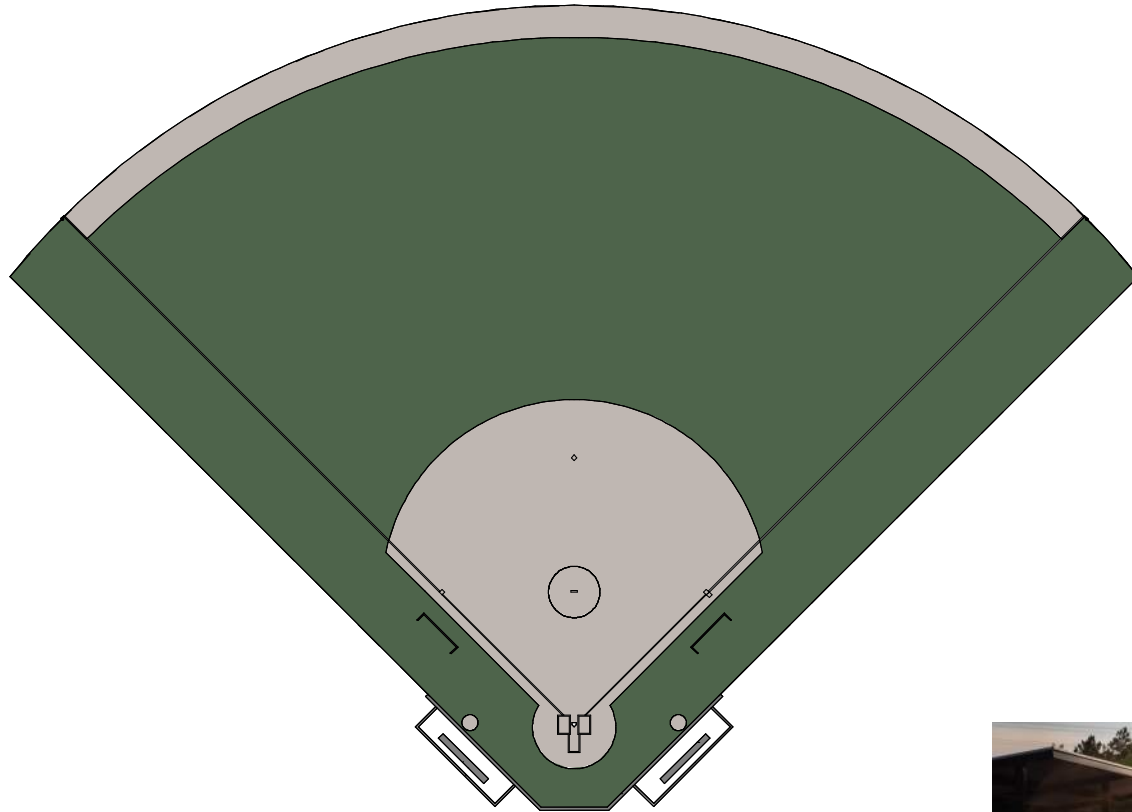

	Field Class			
	1	2	3	4
<b>Player Safety</b>				
Safety Fencing at Players Bench	REQ	REQ	REQ	REQ
Safety Fencing at Bullpen	REQ	PREF	OPT	NOT REQ
Non-overlapping Field	REQ	REQ	OPT	NOT REQ
<b>Field Characteristics</b>				
Lighting	REQ	REQ	PREF	NOT REQ
Outfield Fencing	REQ	REQ	OPT	NOT REQ
Semi-permanent Outfield Fencing	REQ	REQ	OPT	NOT REQ
Foul Line Poles	REQ	REQ	OPT	NOT REQ
Warning Track	REQ	PREF	OPT	NOT REQ
<b>Play Characteristics</b>				
Full Backstop	REQ	REQ	PREF	OPT
Adjustable Bases	REQ	REQ	PREF	OPT
Permanent Bases	REQ	REQ	PREF	OPT
Scoreboard	REQ	REQ	NOT REQ	NOT REQ
Dugouts	REQ	REQ	REQ	OPT
Players Benches	REQ	REQ	PREF	OPT
Drinking Fountain	REQ	REQ	PREF	OPT
Electricity Source	REQ	REQ	PREF	OPT
Batting Cage	REQ	REQ	PREF	OPT
Team Equipment Shed	REQ	PREF	NOT REQ	NOT REQ
<b>Maintenance</b>				
Field Equipment Shed	REQ	REQ	OPT	NOT REQ
Irrigation	REQ	REQ	NOT REQ	NOT REQ
Weed-free Infield	REQ	REQ	REQ	PREF
Rain Cover	REQ	REQ	NOT REQ	NOT REQ
<b>Spectating</b>				
Seating	REQ	REQ	OPT	NOT REQ
Protected Seating	REQ	REQ	OPT	NOT REQ
Covered Seating	REQ	REQ	NOT REQ	NOT REQ
Concessions	REQ	OPT	NOT REQ	NOT REQ

\* REQ = Required PREF = Preferred OPT = Optional NOT REQ = Not Required N/A = Not Available



\* Men's Softball at Xcel Field Park

# Softball Field Classifications - Level 3

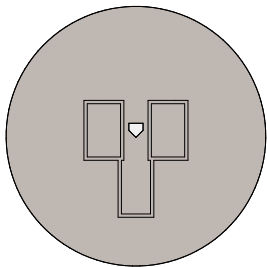
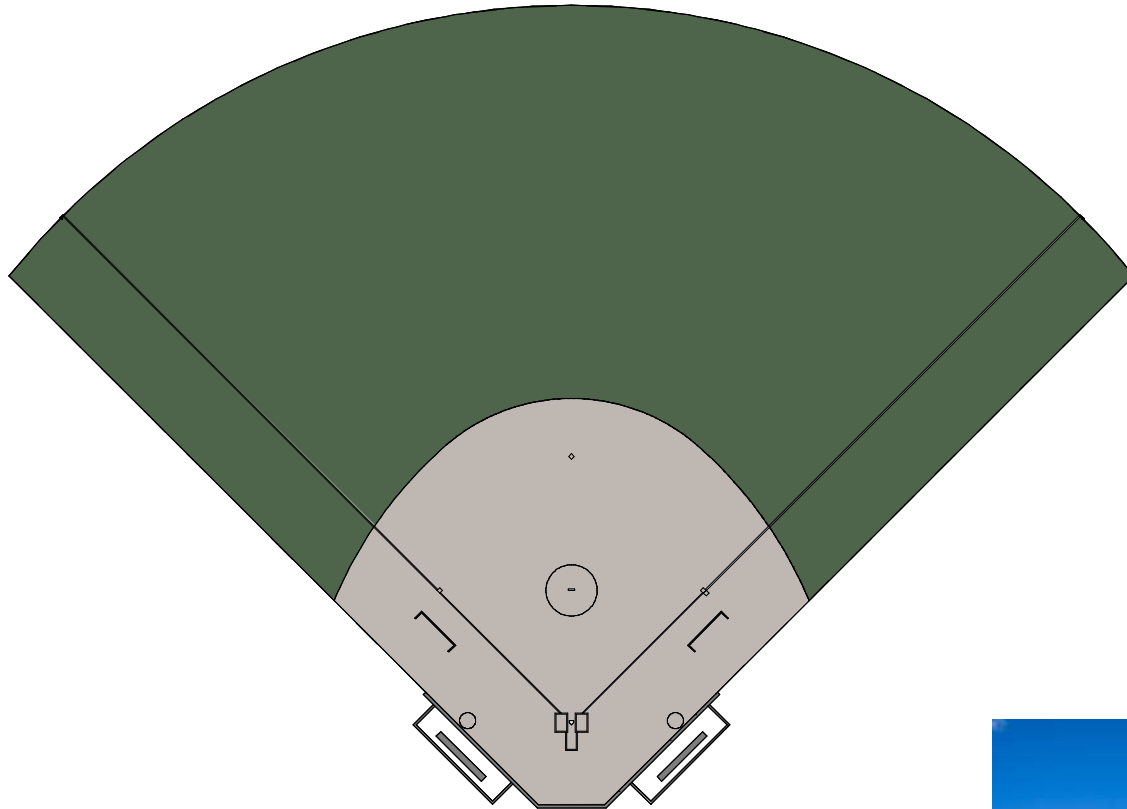

	Field Class			
	1	2	3	4
<b>Player Safety</b>				
Safety Fencing at Players Bench	REQ	REQ	REQ	REQ
Safety Fencing at Bullpen	REQ	PREF	OPT	NOT REQ
Non-overlapping Field	REQ	REQ	OPT	NOT REQ
<b>Field Characteristics</b>				
Lighting	REQ	REQ	PREF	NOT REQ
Outfield Fencing	REQ	REQ	OPT	NOT REQ
Semi-permanent Outfield Fencing	REQ	REQ	OPT	NOT REQ
Foul Line Poles	REQ	REQ	OPT	NOT REQ
Warning Track	REQ	PREF	OPT	NOT REQ
<b>Play Characteristics</b>				
Full Backstop	REQ	REQ	PREF	OPT
Adjustable Bases	REQ	REQ	PREF	OPT
Permanent Bases	REQ	REQ	PREF	OPT
Scoreboard	REQ	REQ	NOT REQ	NOT REQ
Dugouts	REQ	REQ	REQ	OPT
Players Benches	REQ	REQ	PREF	OPT
Drinking Fountain	REQ	REQ	PREF	OPT
Electricity Source	REQ	REQ	PREF	OPT
Batting Cage	REQ	REQ	PREF	OPT
Team Equipment Shed	REQ	PREF	NOT REQ	NOT REQ
<b>Maintenance</b>				
Field Equipment Shed	REQ	REQ	OPT	NOT REQ
Irrigation	REQ	REQ	NOT REQ	NOT REQ
Weed-free Infield	REQ	REQ	REQ	PREF
Rain Cover	REQ	REQ	NOT REQ	NOT REQ
<b>Spectating</b>				
Seating	REQ	REQ	OPT	NOT REQ
Protected Seating	REQ	REQ	OPT	NOT REQ
Covered Seating	REQ	REQ	NOT REQ	NOT REQ
Concessions	REQ	OPT	NOT REQ	NOT REQ

\* REQ = Required PREF = Preferred OPT = Optional NOT REQ = Not Required N/A = Not Available



\* 18U Softball at Bottineau Field Park

# Softball Field Classifications - Level 4

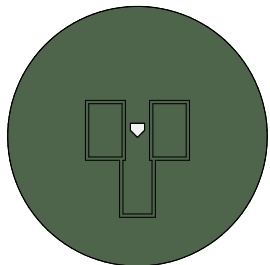
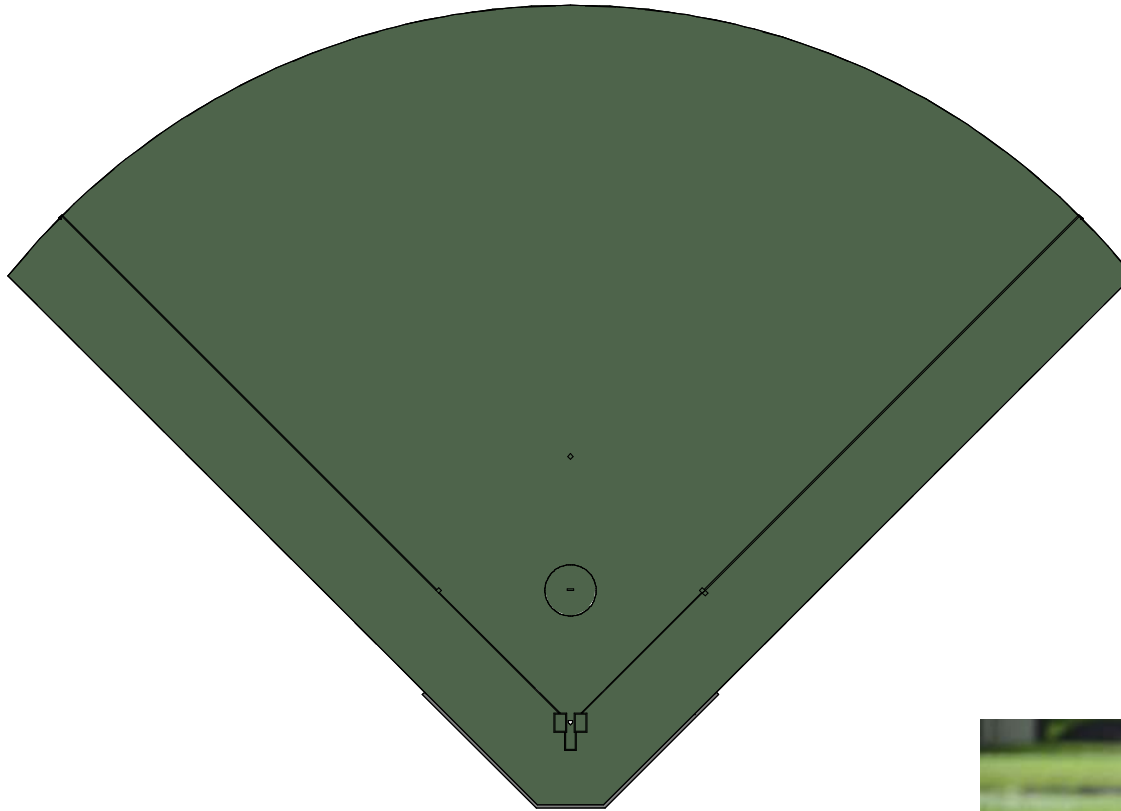

	Field Class			
	1	2	3	4
<b>Player Safety</b>				
Safety Fencing at Players Bench	REQ	REQ	REQ	REQ
Safety Fencing at Bullpen	REQ	PREF	OPT	NOT REQ
Non-overlapping Field	REQ	REQ	OPT	NOT REQ
<b>Field Characteristics</b>				
Lighting	REQ	REQ	PREF	NOT REQ
Outfield Fencing	REQ	REQ	OPT	NOT REQ
Semi-permanent Outfield Fencing	REQ	REQ	OPT	NOT REQ
Foul Line Poles	REQ	REQ	OPT	NOT REQ
Warning Track	REQ	PREF	OPT	NOT REQ
<b>Play Characteristics</b>				
Full Backstop	REQ	REQ	PREF	OPT
Adjustable Bases	REQ	REQ	PREF	OPT
Permanent Bases	REQ	REQ	PREF	OPT
Scoreboard	REQ	REQ	NOT REQ	NOT REQ
Dugouts	REQ	REQ	REQ	OPT
Players Benches	REQ	REQ	PREF	OPT
Drinking Fountain	REQ	REQ	PREF	OPT
Electricity Source	REQ	REQ	PREF	OPT
Batting Cage	REQ	REQ	PREF	OPT
Team Equipment Shed	REQ	PREF	NOT REQ	NOT REQ
<b>Maintenance</b>				
Field Equipment Shed	REQ	REQ	OPT	NOT REQ
Irrigation	REQ	REQ	NOT REQ	NOT REQ
Weed-free Infield	REQ	REQ	REQ	PREF
Rain Cover	REQ	REQ	NOT REQ	NOT REQ
<b>Spectating</b>				
Seating	REQ	REQ	OPT	NOT REQ
Protected Seating	REQ	REQ	OPT	NOT REQ
Covered Seating	REQ	REQ	NOT REQ	NOT REQ
Concessions	REQ	OPT	NOT REQ	NOT REQ

\* REQ = Required PREF = Preferred OPT = Optional NOT REQ = Not Required N/A = Not Available



\* Youth Softball at Pearl Park



**Flexi Ball**  
Low Compression 1

**Diamond**  
DFX-LC1 OL

OFFICIAL  
LEAGUE

OFFICIAL  
LEAGUE

**Flexi Ball**  
Low Compression 1

**Diamond**  
DFX-LC1 OL

OFFICIAL  
LEAGUE

**Diamond**  
DFX-LC1 OL

OFFICIAL  
LEAGUE

## Field Materials Design Intent Standard

Baseball and softball fields rely heavily on the use of high-quality materials and specialized equipment, which are instrumental in ensuring the fields' quality and durability. These materials and tools are selected for their ability to withstand the rigors of frequent play and varying weather conditions, ensuring the field's longevity. Although high-quality materials are preferred, those material selection can be determined by the [Level of Classification of Field](#) or current conditions of each field.

Key materials in field construction include high-grade turf, either natural or synthetic, tailored to specific environmental conditions and usage patterns. For natural grass fields, a blend of grass types is often chosen for optimal growth, resilience, and color. Synthetic turf, on the other hand, involves advanced fibers that mimic the feel and bounce of natural grass, while offering greater durability and lower maintenance requirements.

Infield soil mix, a critical component of the baseball diamond, is another crucial material. It is typically a carefully balanced mixture of sand, clay, and silt, providing the right combination of firmness, drainage, and playability. The choice of infield mix can significantly affect the ball's behavior on the field, making it an essential factor in field construction.

Other essential equipment includes irrigation systems, lighting photometrics of the playing field, field fencing, player protection, spectator safety, and specialized equipment that make up today's ballfield design.



# Field Surfaces Design Intent Standard

## Infield Soil - Ag Lime

Every baseball and softball team needs a verdant, lush field to play on, and effective irrigation design is paramount for maintaining the grass in that field. Installing a reliable irrigation system throughout your baseball field is crucial to the success of the field and the team's performance and reputation.



## Outfield Soil - TBD

Every baseball and softball team needs a verdant, lush field to play on, and effective irrigation design is paramount for maintaining the grass in that field. Installing a reliable irrigation system throughout your baseball field is crucial to the success of the field and the team's performance and reputation.



### **SPECIFICATIONS**

- Provide Standard Zone Irrigation Design with Looped Mainline
- Rain Sensor Irrigation Controller
- Quick Couplers located along field lines near the dugout, and one in grass area behind second base

Material Selection can vary by [Level of Classification of Field](#).

- Rain Bird or approved equal.

### **SPECIFICATIONS**

- Provide Standard Zone Irrigation Design with Looped Mainline
- Rain Sensor Irrigation Controller
- Quick Couplers located along field lines near the dugout, and one in grass area behind second base

Material Selection can vary by [Level of Classification of Field](#).

- Rain Bird or approved equal.

## Infield Seed Mix - TBD

Every baseball and softball team needs a verdant, lush field to play on, and effective irrigation design is paramount for maintaining the grass in that field. Installing a reliable irrigation system throughout your baseball field is crucial to the success of the field and the team's performance and reputation.



### **SPECIFICATIONS**

- Provide Standard Zone Irrigation Design with Looped Mainline
- Rain Sensor Irrigation Controller
- Quick Couplers located along field lines near the dugout, and one in grass area behind second base

Material Selection can vary by [Level of Classification of Field](#).

- Rain Bird or approved equal.

## Outfield Seed Mix - TBD

Every baseball and softball team needs a verdant, lush field to play on, and effective irrigation design is paramount for maintaining the grass in that field. Installing a reliable irrigation system throughout your baseball field is crucial to the success of the field and the team's performance and reputation.



### **SPECIFICATIONS**

- Provide Standard Zone Irrigation Design with Looped Mainline
- Rain Sensor Irrigation Controller
- Quick Couplers located along field lines near the dugout, and one in grass area behind second base

Material Selection can vary by [Level of Classification of Field](#).

- Rain Bird or approved equal.

## Batting Cage Design Intent Standard

Batting cages may be required based on [Level of Classification of Field](#) and are located on one or both sides of the field. Each batting cage shall have a minimum inside dimension of 70 feet by 15 feet or 60 feet by 15 feet (for youth baseball or softball use). The floor shall be a 4-inch thick concrete pad with a centered floor drain. The perimeter fencing shall be 12 feet high chain link fence supported by galvanized steel posts, maximum 8 feet on center.

Each batting cage shall have two 120V outlets, located at the door end of the cage. Each batting cage shall have its own door with lockable latch. The batting cages shall be equipped with a pitching machine and sports turf homeplate mat.



### SPECIFICATIONS

- Provide Standard galvanized finish
  - Black coated **LEVEL 1 EXAMPLE**
- Posts shall be standard weight (Schedule 40) and hot-dip galvanized pipe meeting the requirements of ASTM F1083.
- Corner Posts, Warm-up Board Posts and Gate Posts: Shall be nominal 3 inch O.D. schedule 40, galvanized steel pipe, unless noted otherwise. Posts shall be of sufficient length to be set in concrete frost footings as noted on the drawings.
- Line Posts: Shall be nominal 2-3/8 inches O.D. schedule 40, galvanized steel pipe.
- Rails: Shall be nominal 1-5/8" (min) O.D., schedule 40 galvanized steel pipe, plain end, sleeve coupled
- Post Caps: Sized to post diameter, set screw retainer, cast steel galvanized.
- Fabric: Shall be woven from 6-gauge or 9-gauge (as indicated in the Plans) galvanized steel wire in a 2-inch interwoven Diamond mesh. Fabric wire shall have a minimum tensile strength of 80,000 pounds per square inch. Fabric shall be 1-piece vertically for fences up to and including 12 feet high.

## Intent Detail

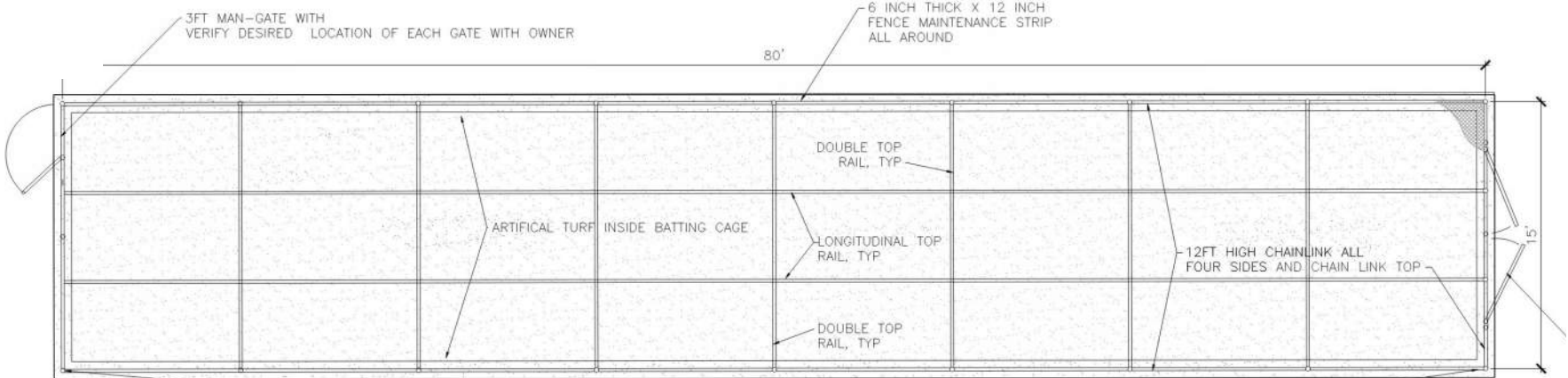

PLAN VIEW

PLACE FENCING ON LEFT FIELD FENCE LINE IF ALTERNATE IS AWARDED - BATTING CAGE FENCING WILL BE USED IN PLACE OF BASE BID FENCING AT THIS LOCATION

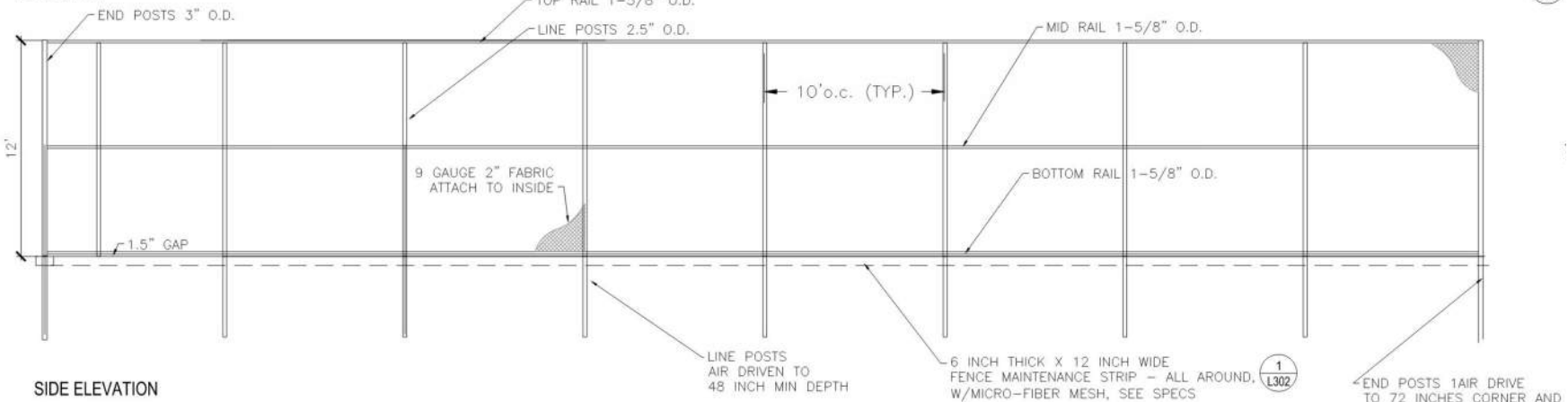

SIDE ELEVATION

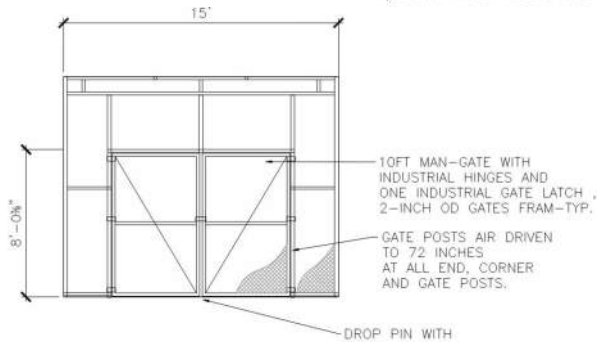
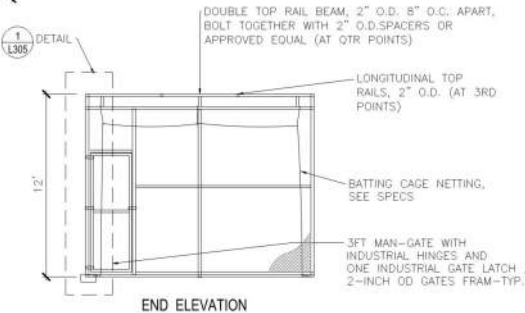

# Field Fence Design Intent Standard

Permanent outfield fencing shall be required where there is no field overlay and depending on [Level of Classification of Field](#). All permanent fencing shall be a minimum 8 feet high and constructed of 6-gauge chain link, unless noted on plans. The fences shall have top, center, and bottom rails. For permanent fencing there shall be concrete mow strips and the fence will be covered with windscreen fabric, optional depending on [Level of Classification of Field](#).

When multi-sport field overlay occurs, semi-permanent fencing shall be provided that is 5 feet high made of flexible mesh - see [Temporary Fencing Design Intent Standards](#).



## Design Intent Detail

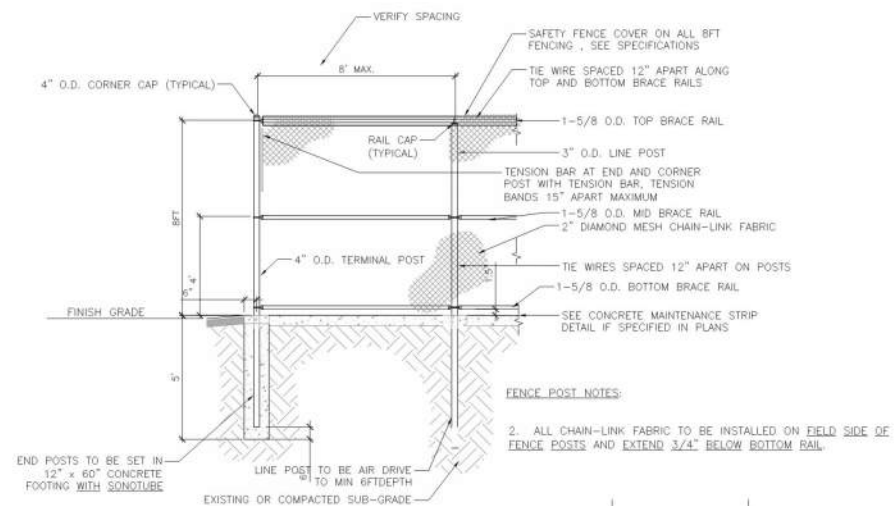

## SPECIFICATIONS

- Provide Standard galvanized finish  
-Black coated **LEVEL 1 EXAMPLE**
- Fencing, posts, and rails, see batting cage specification.
- Fence Caps - suggested and depends on [Level of Classification of Field](#).

## LEVEL 1 EXAMPLE

- Gopher Sport, Kodiak Sports, PW Athletics or approved equal.
- 4-1/2" Dia. Polyethylene, pre-slit, UV-protected, standard color selection with color-matched ties.

# Field Maintenance Gate Design Intent Standard



Field maintenance gates shall be provided on left and right side of the field fencing. If field has a paved trail near gate access, provide a paved entrance to the maintenance gate.

Width of maintenance gate shall be a minimum width 10' and minimum height 4'. Fence caps are suggested.

## Design Intent Detail

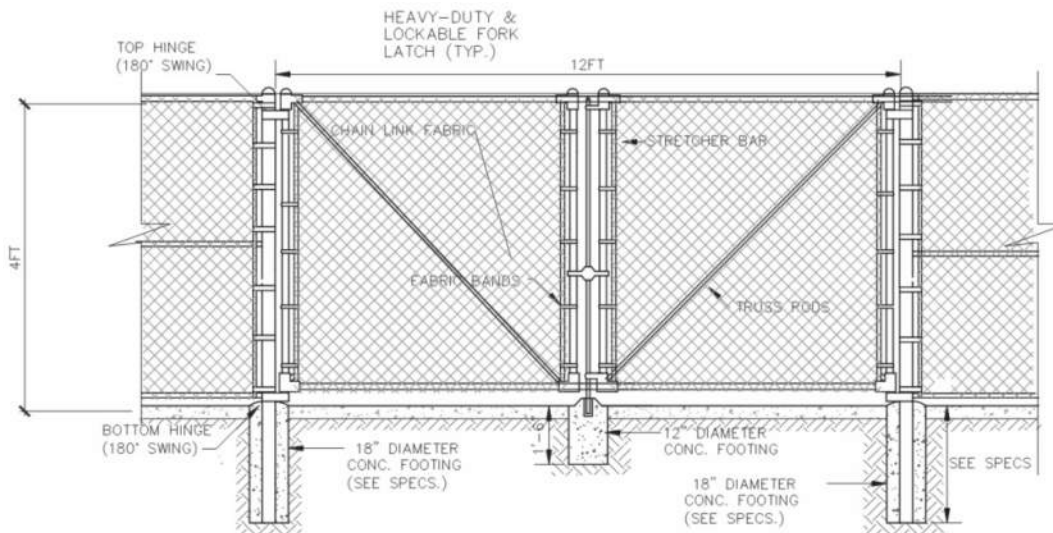

### NOTES:

1. FENCE FABRIC SHALL BE SECURED TO GATE FRAMES WITH KNUCKLED SELVAGE ALONG ALL EDGES FOR ALL TYPES CHAIN LINK FENCE INSTALLATIONS.
2. REFER TO SPECIFICATIONS FOR ALL PIPE SIZING, WIRE FABRIC GAUGES, FOOTING SIZES & OTHER APPLICABLE INFORMATION.
3. ALL CONCRETE FOOTINGS AROUND POSTS AT GROUND LINE SHALL BE MOUNDED & SLOPED FOR POSITIVE DRAINAGE.

### SPECIFICATIONS

- Provide Standard galvanized finish  
-Black coated **LEVEL 1 EXAMPLE**

### LEVEL 1 EXAMPLE

- Gate perimeter frame shall be nominal 2-inch O.D. Schedule 40 pipe.
- Provide additional horizontal and vertical members to ensure proper gate operation and for attachment of fabric, hardware, and accessories.
- Assemble gate frames by welding fittings and rivets for rigid connections.
- Use same fabric specified for fence. Install fabric with stretcher bars at vertical edges and tie at top and bottom edges. Attach stretcher bars to gate frame at 15 inches on center maximum.
- Attach hardware with rivets or by other means which will provide security against removal or breakage.
- Hinges: Pressed steel or malleable iron to suit gate size, non-lift-off type, offset to permit 180 degree swing. Provide 1 pair of hinges for each leaf.
- Latch: Sized to post diameter, cast galvanized steel with a positive-type latching device, provision for padlocking and hinges as required to secure gate.
- Keeper: Provide semi-automatic outer catches to secure gates in open position.

# Backstop Design Intent Standard



Backstop shall be surrounded by a 6 inch high concrete curb or block wall on the outside of the backstop to keep water from draining onto the field. All concrete surrounding the backstop shall slope 1 percent away from the field.

Backstops and wings shall be minimum 25 feet in height. Back of backstop, centered behind the home plate, shall be 30 feet long, with each wing extending 30 feet parallel to each foul line.

## SPECIFICATIONS

- Provide Standard Backstop Dimensions
- Height may vary
- Installation with concrete curb or block wall
- Additional safety netting is optional, depending on [Level of Classification of Field](#) and field conditions.

Material Selection can vary by [Level of Classification of Field](#).

## SPECIFICATIONS

- Provide Standard galvanized finish
  - Black coated **LEVEL 1 EXAMPLE**
- Posts shall be standard weight (Schedule 40) and hot-dip galvanized pipe meeting the requirements of ASTM F1083.
- Posts, Shall be nominal 4 inch O.D. schedule 40, galvanized steel pipe, unless noted otherwise. Posts shall be of sufficient length to be set in concrete frost footings as noted on the drawings.
- Line Posts: Shall be nominal 2-3/8 inches O.D. schedule 40, galvanized steel pipe.
- Rails: Shall be nominal 1-5/8" (min) O.D., schedule 40 galvanized steel pipe, plain end, sleeve coupled
- Post Caps: Sized to post diameter, set screw retainer, cast steel galvanized.
- Fabric: Shall be woven from 6-gauge or 9-gauge (as indicated in the Plans) galvanized steel wire in a 2-inch interwoven Diamond mesh. Fabric wire shall have a minimum tensile strength of 80,000 pounds per square inch. Fabric shall be 1-piece vertically for fences up to and including 12 feet high.



# Dugout Design Intent Standard

Dugouts provide protection for players and coaches from all elements. The design of the dugout should allow for unobstructed views for teams.

Dugouts shall be located along the first and third baselines, behind the backstop wings or integrated into the field fencing. They shall be installed on concrete pads at field grade that are sloped away from the field, and surrounded by an 8 foot high chain link. Optional black windscreen fabric on three sides of the dugout. The dugouts shall be 30 feet long, 10 feet wide, and equipped with a 25 foot long

Dugout roofs are optional and provided depending on [Level of Classification of Field](#).



## SPECIFICATIONS

- Provide Standard galvanized finish
  - Black coated **LEVEL 1 EXAMPLE**
- Fencing, posts, rails, and roof depends on [Level of Classification of Field](#).

## LEVEL 1 EXAMPLE

- Beacon Athletics, or approved equal.
- Prefabricated Premium Team Dugouts 10' x 30' Northern Style.
- **Dimensions:** 10'D x 30'L x 8'H
- All-steel construction (A500 square structural steel tubing)
- 26-gauge galvanized metal roof panel & steel support columns are powder coated
- Standard Colors Available

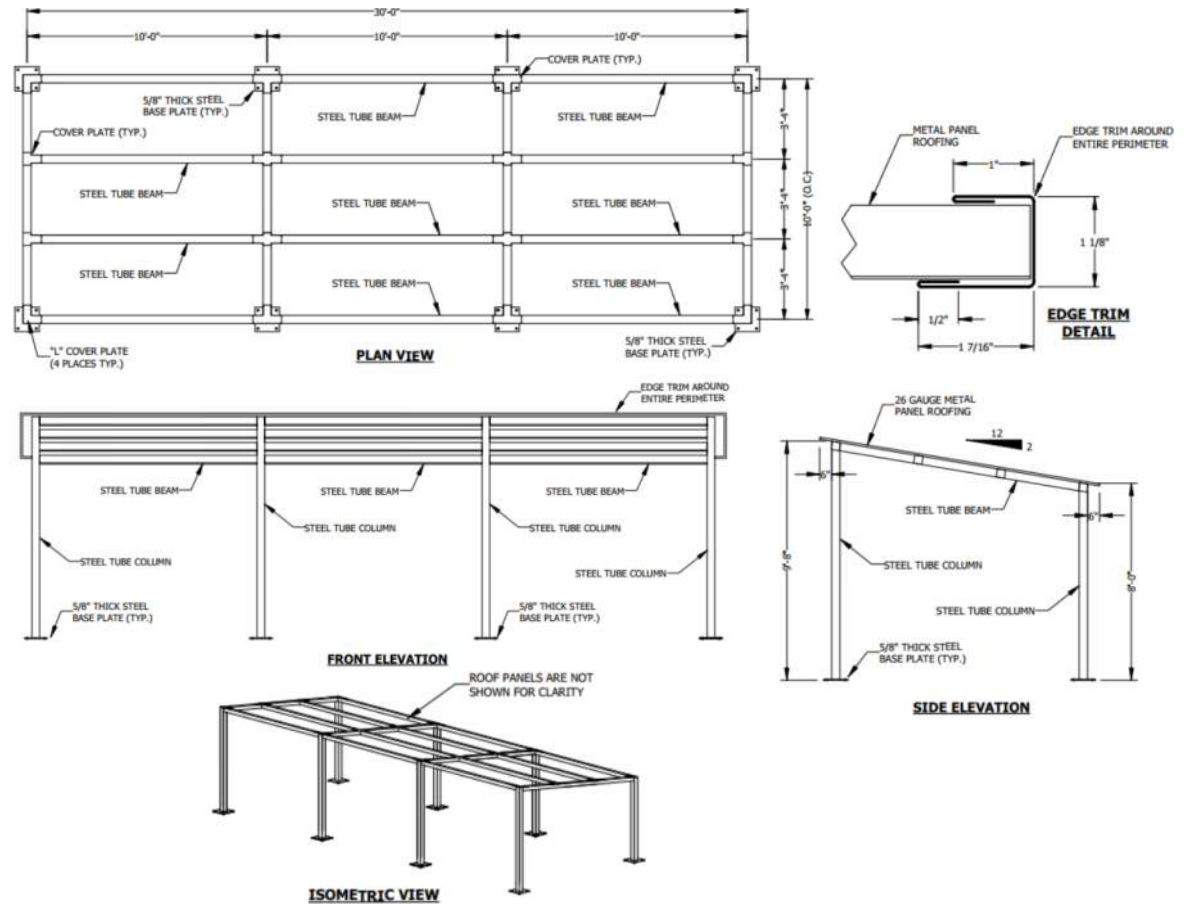

## FeaturesA

- These premium dugouts arrive ready to assemble. Prefabricated and pre-engineered with all fasteners concealed within tubing to avoid corrosion and provide better safety.
- Northern U.S. dugouts designed to handle snow loads.
- Optional stamped engineering report for an additional chargeA
- Please Note: Optional chain-link fencing not included with dugouts - must be provided by others.A

# Foul Pole Design Intend Standard



Foul Poles are installed directly on the foul line with the wing facing in towards the field of play. No part of the foul pole should extend outside of the foul line. The “Foul Line” and “Foul Pole” are in play.

All poles within or in the vicinity of the playing area that are not protected by a fence shall have 6 feet high pole pads.

## Design Intent Detail

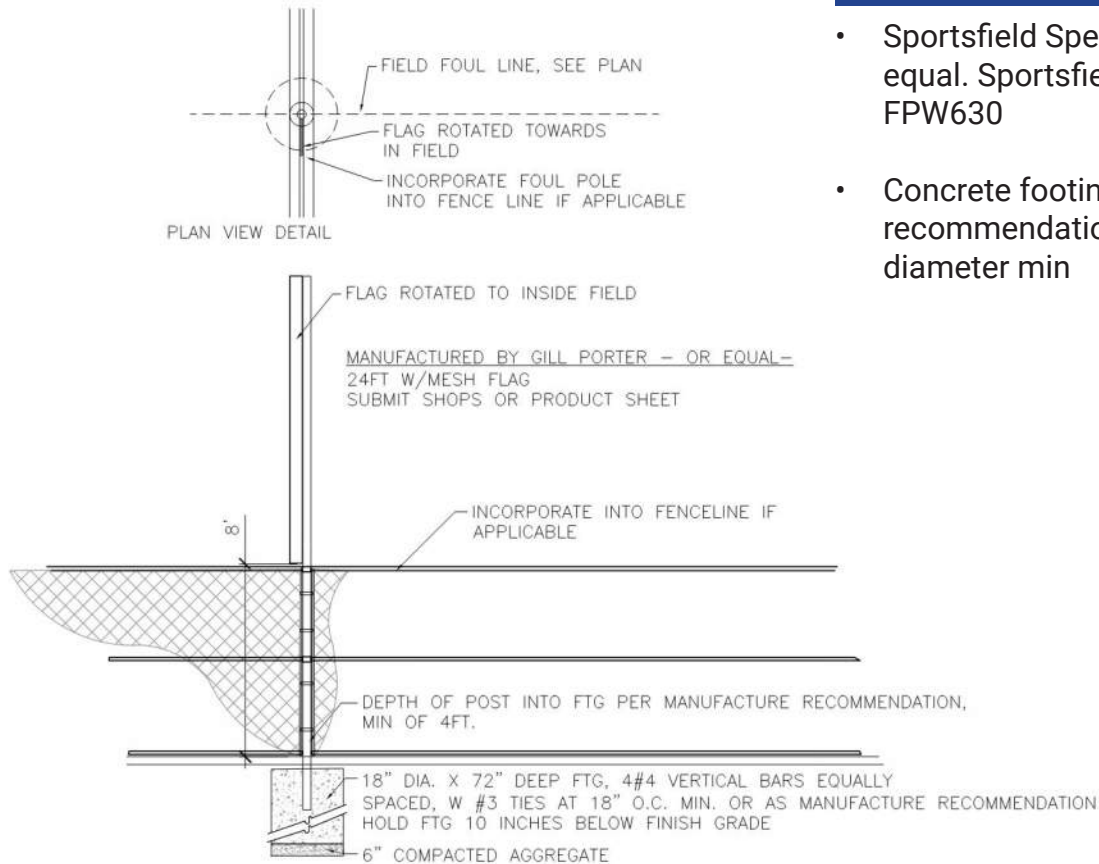

## SPECIFICATIONS

- Provide Standard Foul Pole
- Metal wing is optional
- Direct bury is typical installation method
- Yellow powder coated finish
- Height may vary

Material Selection can vary by [Level of Classification of Field](#).

## LEVEL 1 EXAMPLE

- Sportsfield Specialties or approved equal. Sportsfield specialties model # FPW630
- Concrete footings as per manufacturer recommendations – 5ft depth min, 24" diameter min

# Scoreboard Design Intent Standard



Scoreboards are an optional feature for baseball and softball fields. See [Level of Classification of Field](#).

Scoreboards are to be located outside field of play, if no outfield fencing is provided add padding to scoreboard base.

## SPECIFICATIONS

- Provide Standard Scoreboard with Wireless Controls.
- Concrete footings as per manufacturer recommendations

Material Selection can vary by [Level of Classification of Field](#).

## Design Intent Detail

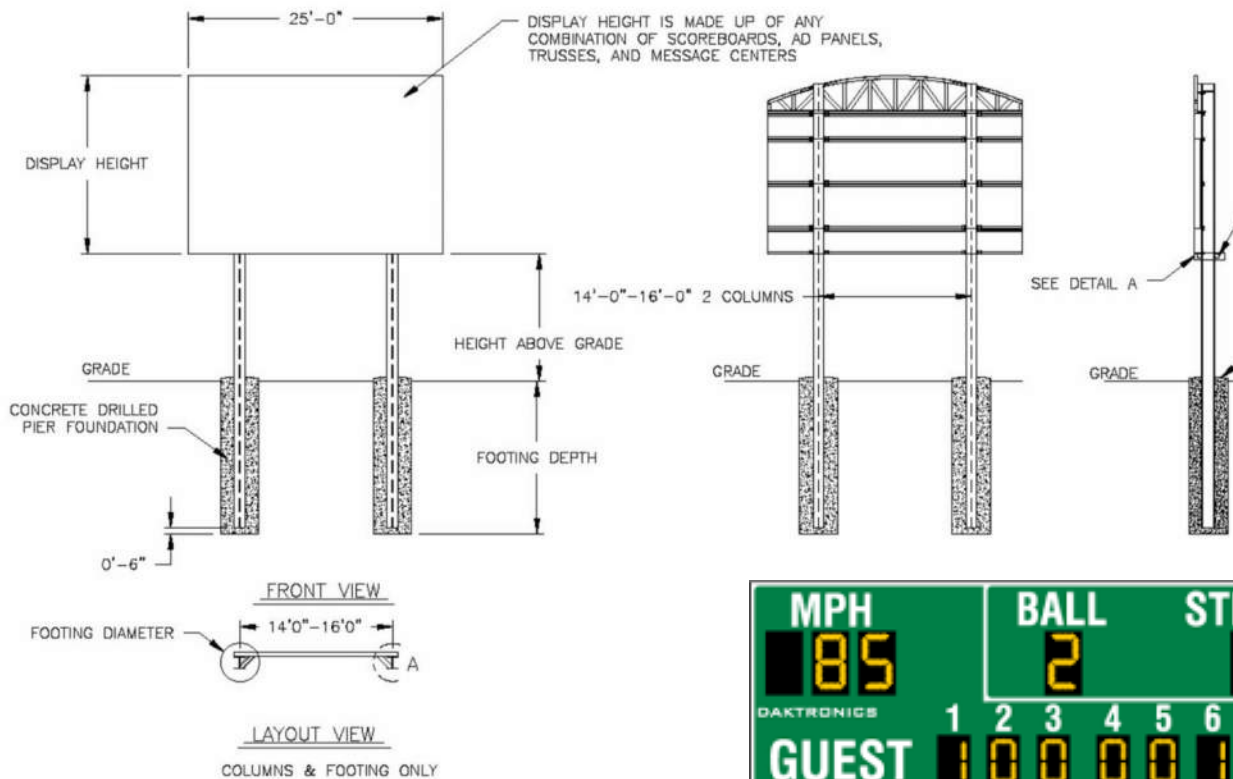

## LEVEL 1 EXAMPLE

- Daktronics, Inc. or approved equal. Daktronics model # BA-2125-AmberLED Digit Baseball Scoreboard including MX-1 App-Based Control, Boarder Stripe and Ball/Strike/Out Striping
- Dimensions: 7'-0" (2.13 m) high, 25'-0" (7.62 m) wide, 0'-8" (203 mm) deep
- Base power requirement: 355 W (red/amber digits), 770 W (white digits) with vinyl captions – options may increase wattage
- Color: provide standar colors to choose from.

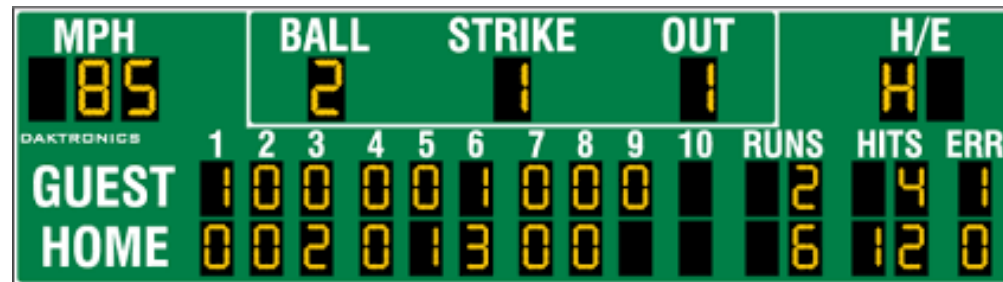

# Safety Netting Design Intent Standard



## SPECIFICATIONS

- Provide Standard galvanized finish  
-Black coated **LEVEL 1 EXAMPLE**
- Height and length may vary

Material Selection can vary by **Level of Classification of Field.**

## LEVEL 1 EXAMPLE

General Requirements:

- Posts shall be straight, Schedule 40 and hot-dip galvanized pipe meeting the requirements of ASTM A120.
- Post Caps: Sized to post diameter, set screw retainer, cast steel galvanized.
- Ground Sleeves with Stop Bolt.
- Components shall be hot-dip galvanized.

## Design Intent Detail

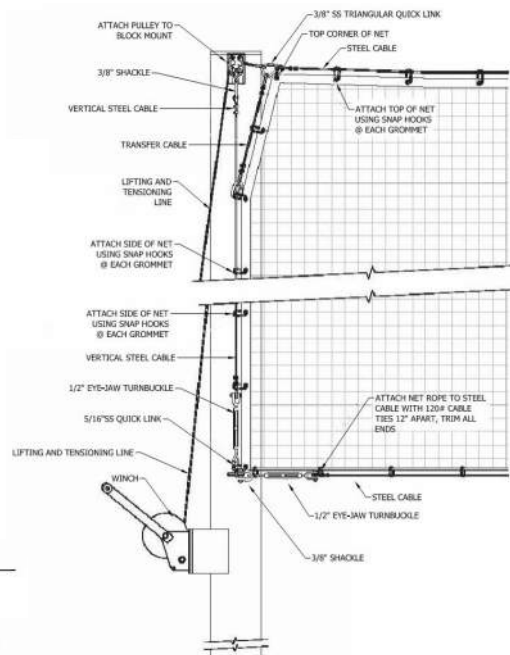
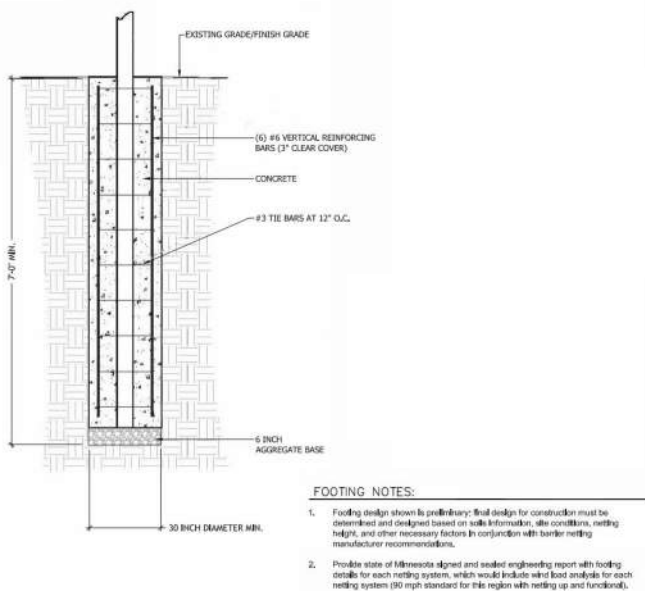

Barrier Netting:

- Material: Shall be black, #36, twisted, knotted nylon,
- Mesh: 1-3/4" square
- Edging: Sewn hems with grommets on top side with sewn 1/4-inch sewn rope border on sides and bottom of netting.

Hardware:

- Must include all cabling/finishing's, winches/pulleys, attachment and tensioning hardware to facilitate Beacon in-line hoistable, configurable barrier netting system
- Hardware shall be hot-dip galvanized. Independent 1/4-inch diameter 7x19 steel cable.

# Home Plate and Bases Design Intent Standard



Home plate, the bases, and the pitching rubber shall be provided at the time of construction, but shall be installed by MPRB. For ballfields with turf infields, a pitchers mound cover and a home plate cover shall be provided.

## Design Intent Detail

### SPECIFICATIONS

- Provide Standard Home Plate and Bases
- Clay Base is typical installation method for Home Plate
- One set of steel anchors for bases to be installed, unless noted. Refer to [Field Dimensions Table](#) for dimension locations.

Material Selection can vary by [Level of Classification of Field](#).

### LEVEL 1 EXAMPLE

- One set of three Hollywood Impact Bases or approved equal, heavy-duty molded rubber construction, chevron design to allow base to compress upon impact with 1-1/2-inch anchors and rubber plugs.
- Base anchors with anchor covers at each of the baseline lengths indicated in the plans.
- One Hollywood Bury-All home plate or approved equal, all rubber construction, waffle bottom design, 3-inch thickness, min. weight 24 lbs.
- One Hollywood Double Stanchion or approved equal, removable, regulation 6-inch x 24-inch with anchors.
- Pitching rubber anchors with anchor covers at each of the pitching lengths indicated in the plans.

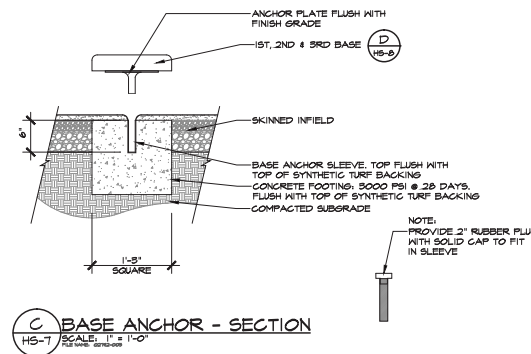
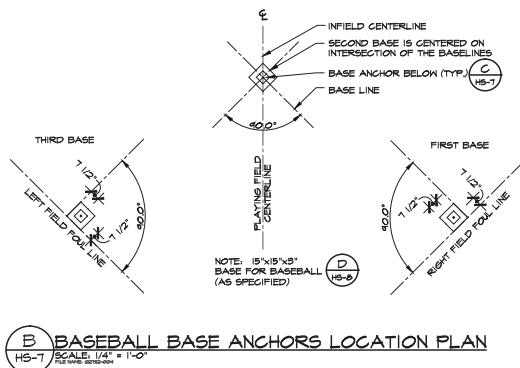
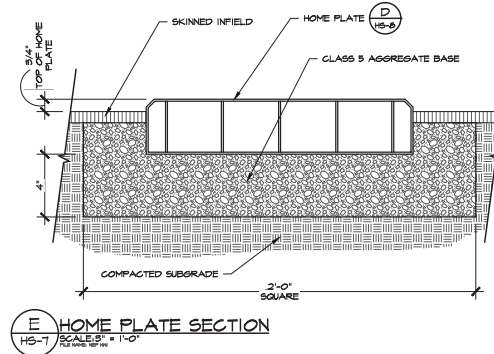
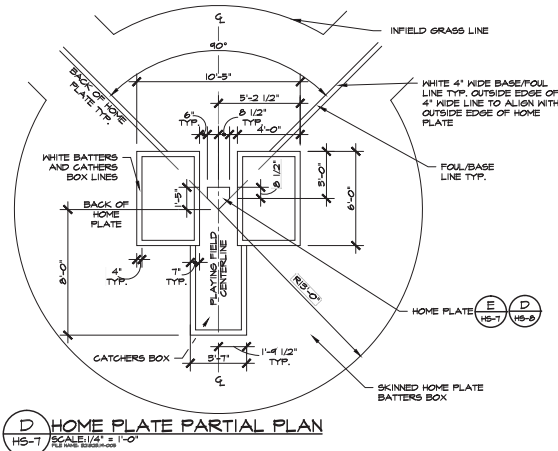

# Spectator Seating Design Intent Standard



## SPECIFICATIONS

- Number of rows – dependent on field needs. Suggest minimum of 5 rows (net seating = 90)
- Galvanized steel understructure
- 2 x 10 anodized aluminum seat planks
- Vertical picket guardrail system
- Confirm if bleachers should be transportable or, if bleachers should be secured

## LEVEL 1 EXAMPLE

Acceptable Manufacturers/Vendors:

- National Recreation Systems
  - (local rep. St. Croix Recreation)

Spectator seating should be located in an unobstructed area minimum 4 feet wide in front of and on each side of the bleachers, and minimum 6 feet wide at the rear of the bleachers shall be provided for accessibility. Concrete walkways shall be provided for access to the area.

Spectator seating shall be provided by tiered concrete structures or portable bleachers containing minimum of five (5) rows of seating placed in an area approximately 28 feet with 14 feet. Spectator seating is required on each side of the spectator area. All seating facilities shall conform to ADA Accessibility Regulations.

## Intent Detail

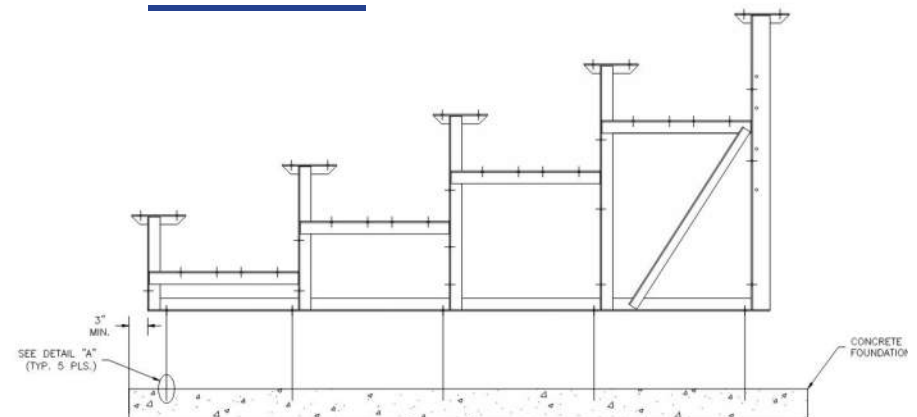

# Temporary Fencing Design Intent Standard

When multi-sport field overlay occurs, semi-permanent fencing shall be provided based on [Level of Classification of Field](#). All semi-permanent fencing shall be a 5 feet in height and constructed of flexible mesh, unless noted on plans. Semi-permanent fencing should include equipment to transport, install, and store all equipment.

## SPECIFICATIONS

- Provide Standard Semi-Permanent Fencing

Material Selection can vary by [Level of Classification of Field](#).

## LEVEL 1 EXAMPLE

- Beacon Athletics or approved equal. SPECTO Outfield Fencing

## PRODUCT FEATURES

- Pole Carts— Easily store and transport foul and intermediate poles. These powder coated, steel frame carts are built to last and haul easily.
- Fencing Cart — Easily roll onto a fencing cart for transportation and/or storage. Simply hook up and haul the powder coated steel cart behind your maintenance vehicle.
- Foul Territory Fencing — Extend your outfield fence with SPECTO® Foul Territory fencing to protect spectators and your foul territory.



# Field Accessories Design Intent Standard

## Pitching Warm-up Bullpen

Every baseball and softball team needs a verdant, lush field to play on, and effective irrigation design is paramount for maintaining the grass in that field. Installing a reliable irrigation system throughout your baseball field is crucial to the success of the field and the team's performance and reputation.



### **SPECIFICATIONS**

- Provide Standard Zone Irrigation Design with Looped Mainline
- Rain Sensor Irrigation Controller
- Quick Couplers located along field lines near the dugout, and one in grass area behind second base

Material Selection can vary by [Level of Classification of Field](#).

- Rain Bird or approved equal.

## Hitting Station



Every baseball and softball team needs a verdant, lush field to play on, and effective irrigation design is paramount for maintaining the grass in that field. Installing a reliable irrigation system throughout your baseball field is crucial to the success of the field and the team's performance and reputation.

### **SPECIFICATIONS**

- Provide Standard Zone Irrigation Design with Looped Mainline
- Rain Sensor Irrigation Controller
- Quick Couplers located along field lines near the dugout, and one in grass area behind second base

Material Selection can vary by [Level of Classification of Field](#).

- Rain Bird or approved equal.

## Movable Pitching Mound

Every baseball and softball team needs a verdant, lush field to play on, and effective irrigation design is paramount for maintaining the grass in that field. Installing a reliable irrigation system throughout your baseball field is crucial to the success of the field and the team's performance and reputation.



### **SPECIFICATIONS**

- Provide Standard Zone Irrigation Design with Looped Mainline
- Rain Sensor Irrigation Controller
- Quick Couplers located along field lines near the dugout, and one in grass area behind second base

Material Selection can vary by [Level of Classification of Field](#).

- Rain Bird or approved equal.

## Additional Accessories

### **ELECTRICAL OUTLETS**

- 30 amp Electrical Outlets
- Located behind the Backstop at Home Plate and behind both Dugouts

### **DRINKING FOUNTAINS**

- ADA Drinking Fountain located within proximity of ballfield

# Irrigation Design Intent Standard

Every baseball and softball team needs a verdant, lush field to play on, and effective irrigation design is paramount for maintaining the grass in that field. Installing a reliable irrigation system throughout your baseball field is crucial to the success of the field and the team's performance and reputation.

Baseball and softball field irrigation design and locations will be determined by [Level of Classification of Field](#).

## SPECIFICATIONS

- Provide Standard Zone Irrigation Design with Looped Mainline
- Rain Sensor Irrigation Controller
- Quick Couplers located along field lines near the dugout, and one in grass area behind second base

Material Selection can vary by [Level of Classification of Field](#).

## LEVEL 1 EXAMPLE

- Rain Bird or approved equal.



## Design Intent Detail

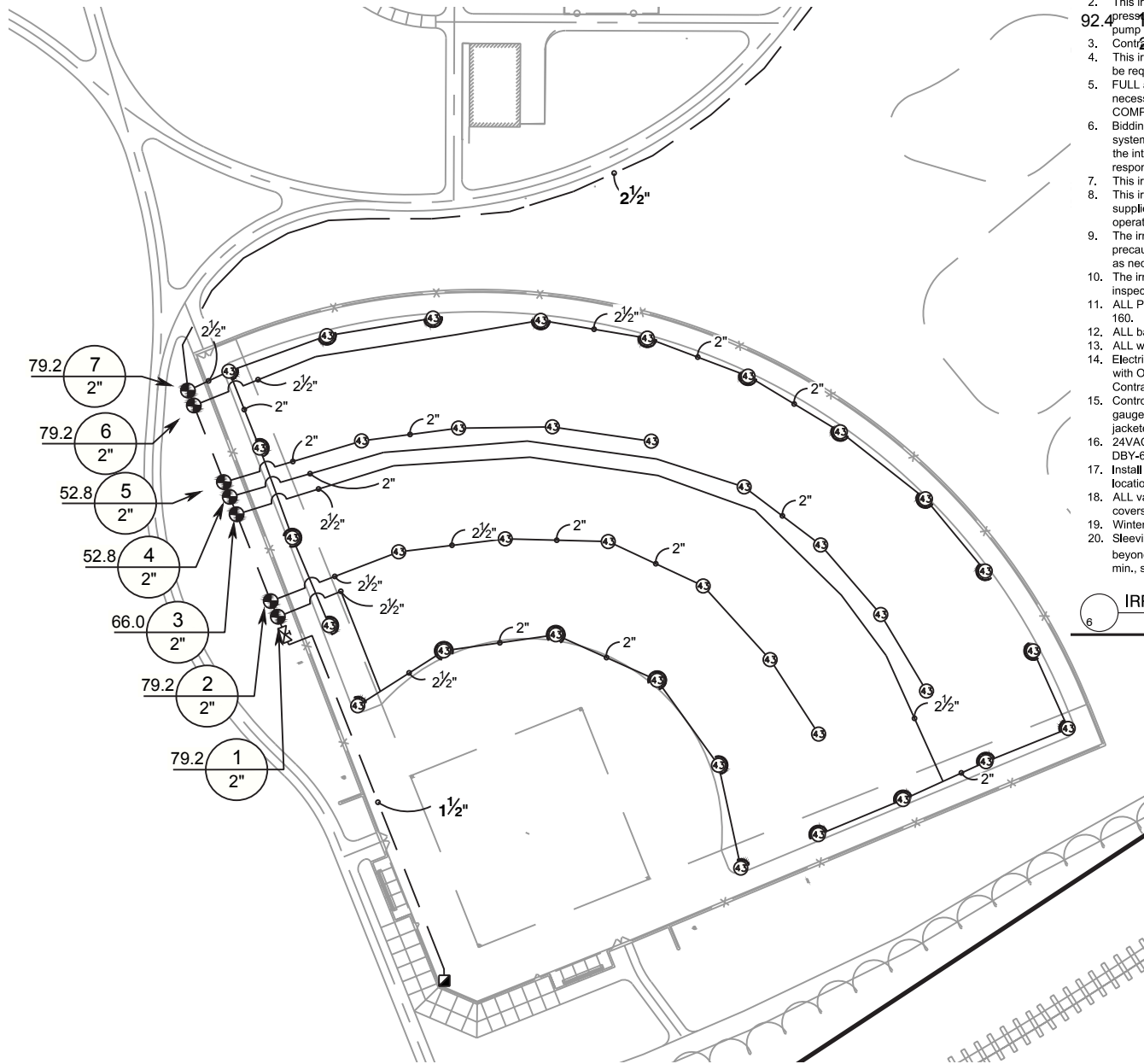

1. DESIGN BASED ON POC ANALYSIS (downstream of meter).
2. This irrigation design is from the point of connection only. This design is based on the pressure and volume indicated in item #1, which is furnished and verified by others. Booster pump may be required if pressure and flow do not meet listed requirements.
3. Contractor shall be responsible to field verify the information in the POC Analysis.
4. This irrigation design is diagrammatic. Adjustments to pipe, valve and/or head placement may be required of contractor.
5. FULL and COMPLETE coverage is required. The irrigation contractor shall make any necessary minor adjustments to the irrigation layout required to achieve FULL and COMPLETE coverage of irrigated areas at no additional cost to owner.
6. Bidding contractors shall become thoroughly familiar with all facets of the proposed irrigation system and the control requirements & specifications. Failure to clarify misunderstandings or the intent of this drawing and/or specifications before submittal of bid shall be the sole responsibility of the contractor.
7. This irrigation system shall be installed as per manufactures specifications.
8. This irrigation design shows necessary materials, but certain other materials may have to be supplied and installed by the irrigation contractor in order to have, upon completion, a fully operational irrigation system.
9. The irrigation contractor shall locate ALL underground utilities, and they shall take every precaution not to damage or disturb such improvements. Coordinate with General Contractor as necessary.
10. The irrigation contractor shall arrange for and pay for any necessary permits and/or inspections required by local agencies or ordinances during the course of construction.
11. ALL PVC piping under continuous pressure shall be Class 200, all other PVC shall be Class 160.
12. ALL backflow devices shall be installed as per local code.
13. ALL wiring as per local code.
14. Electrical power shall be provided to within five (5) feet of controller(s) location. Coordinate with Owners Representative as to the final location of controller(s). Coordinate with Electrical Contractor as required.
15. Control wire shall be solid copper wire U.L. approved for direct burial in ground. Minimum gauge - #14 (#12 for runs over 2000') or as otherwise specified. Decoder wire shall be jacketed. Ground Wire (where applicable) shall be white.
16. 24VAC wire splicing material will be direct burial splice kit as manufactured by 3M, specifically DBY-6 & DBR-6.
17. Install rain sensors on vertical surfaces. Coordinate with Owners Representative as to final location of rain sensor, moisture sensors, weather stations and any additional sensors.
18. ALL valves, quick-couplers and wire splices shall be located in valve boxes with labeled covers and buried flush with grade.
19. Winterization of the irrigation system shall be as per the manufactures specifications.
20. Sleeving is required under ALL walks and roadways. Sleeves shall extend a minimum of 18" beyond edge of walk/roadway and be marked. Wire shall be contained in a separate, 1 1/2" min., sleeve.

IRRIGATION GENERAL NOTES:

---

## Field Lighting Design Intent Standard

The goal is that all fields are lighted for night-time use; however, each park site shall be evaluated for appropriateness for lighting. Lighting will be included at neighborhood parks with athletic fields whenever possible and appropriate. When lights are provided for athletic fields, lighting levels shall be per City of Minneapolis Lighting Standards.

Light poles shall be located behind the backstop, wings parallel to first and third baselines, and outside the area of play. The number of poles and lamps required shall be determined by the field configuration and the photometric measurements. Lighting level requirements vary with [Level of Classification of Field](#). Poles within the fenced playing areas shall be padded.

### SPECIFICATIONS

- Provide Standard Light Pole, Arm and Fixture: Fixture and Pole may depend on [Level of Classification of Field](#), lighting levels, and existing field conditions.



# Design Intent Detail

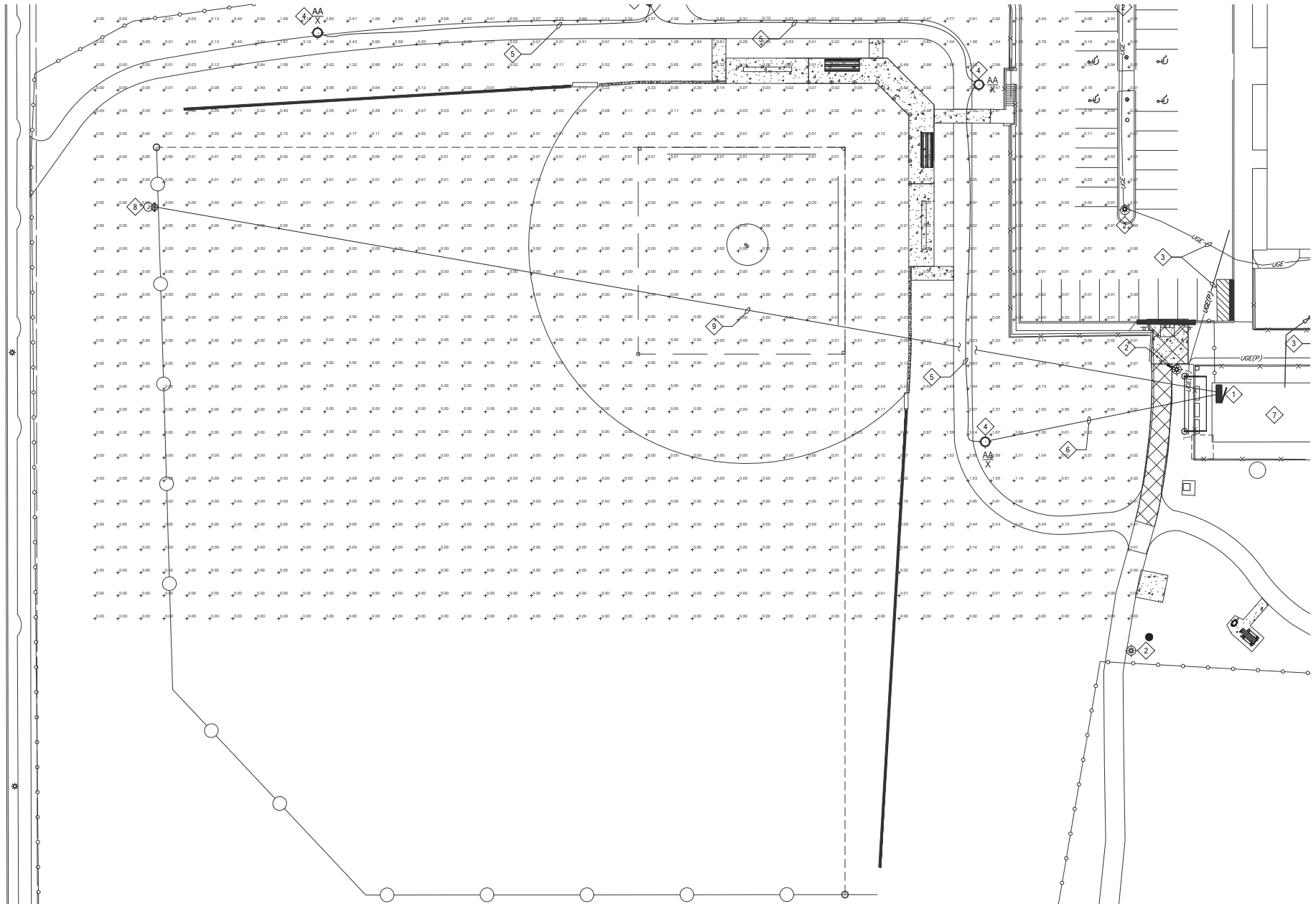



**Minneapolis**  
**Park & Recreation Board**